

EIOFIT

2023

TARIFA PVP

Edición 05 de junio



Sistema completo de accesorios electrosoldables
e inyectados en Polietileno PE100 RC

italsan

Índice

Accesorios de polietileno PE100 RC electrosoldables e inyectados

3	Tubería ELOFIT NADIR
5	Accesorios electrosoldables PE100 RC SDR11 PN16
14	Accesorios de transición PE100 RC SDR11 PN16
18	Bridas
24	Portabridas
29	Collares electrosoldables PE100 RC SDR11 PN16
38	Accesorios inyectados PE100 RC SDR11 PN16
48	Accesorios inyectados PE100 RC SDR17 PN10
58	Máquinas y herramientas

DEFINICIÓN ABREVIATURAS

PFA: Presión de Funcionamiento Admisible (bar)

PN: Presión Nominal (bar)

SDR: parámetro que se utiliza comúnmente como método de clasificación de las tuberías. Es un número convenientemente redondeado, aproximadamente igual a la relación entre el diámetro exterior y el espesor de pared de la tubería.

SDR mín.: valor mínimo de soldabilidad. Nos informa del mínimo espesor necesario en la tubería para la realización de la unión.

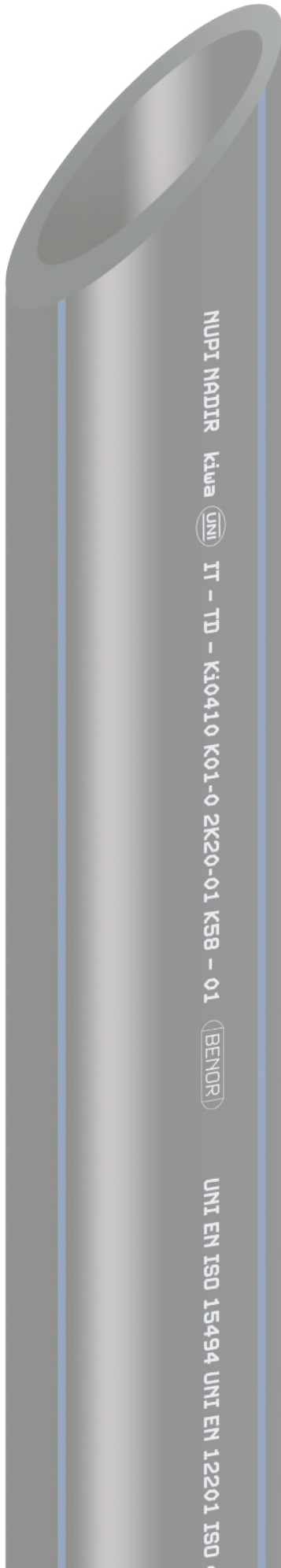

Tubería PE100 RC NADIR

Con Declaración Ambiental de Producto (DAP)





Tubería en polietileno de alta densidad PE100 RC para conducción de agua y saneamiento con presión

La tubería **PE100 RC ELOFIT NADIR** cumple con los requisitos de la normativa aplicable EN 12201 e ISO 4427 para la distribución de fluidos a presión. En particular, es adecuada para el transporte de agua para consumo humano, ya que se ajusta al Decreto Ley nº174/2004, las disposiciones del Decreto Ley nº31/2001 y posteriores enmiendas y adiciones posteriores. En cuanto a las características organolépticas del agua transportada, cumple con la norma EN 1622.

También la tubería **PE100 RC ELOFIT NADIR** cumple con los requisitos de la normativa aplicable EN ISO 15494 de sistemas de canalización en materiales plásticos para el transporte de fluidos en aplicaciones industriales.

Disponible para distribuidores Italsan la tubería en barras de 4 metros en PN16 y diámetro DN50 hasta DN160.

Tubería PE ELOFIT NADIR PE100 RC SDR11 PN16

Referencia	Ø (mm)	Espesor (mm)	Precio (€/m)
TNAD5016B4	50	4,6	Tarifa mensual
TNAD6316B4	63	5,8	Tarifa mensual
TNAD7516B4	75	6,8	Tarifa mensual
TNAD9016B4	90	8,2	Tarifa mensual
TNAD11016B4	110	10,0	Tarifa mensual
TNAD12516B4	125	11,4	Tarifa mensual
TNAD16016B4	160	14,6	Tarifa mensual

Solicitud de tarifa PVP en vigor, a través de nuestra dirección de correo electrónico atencionalcliente@italsan.com o bien al delegado Italsan de la zona.

Atención al cliente: 900 921 957

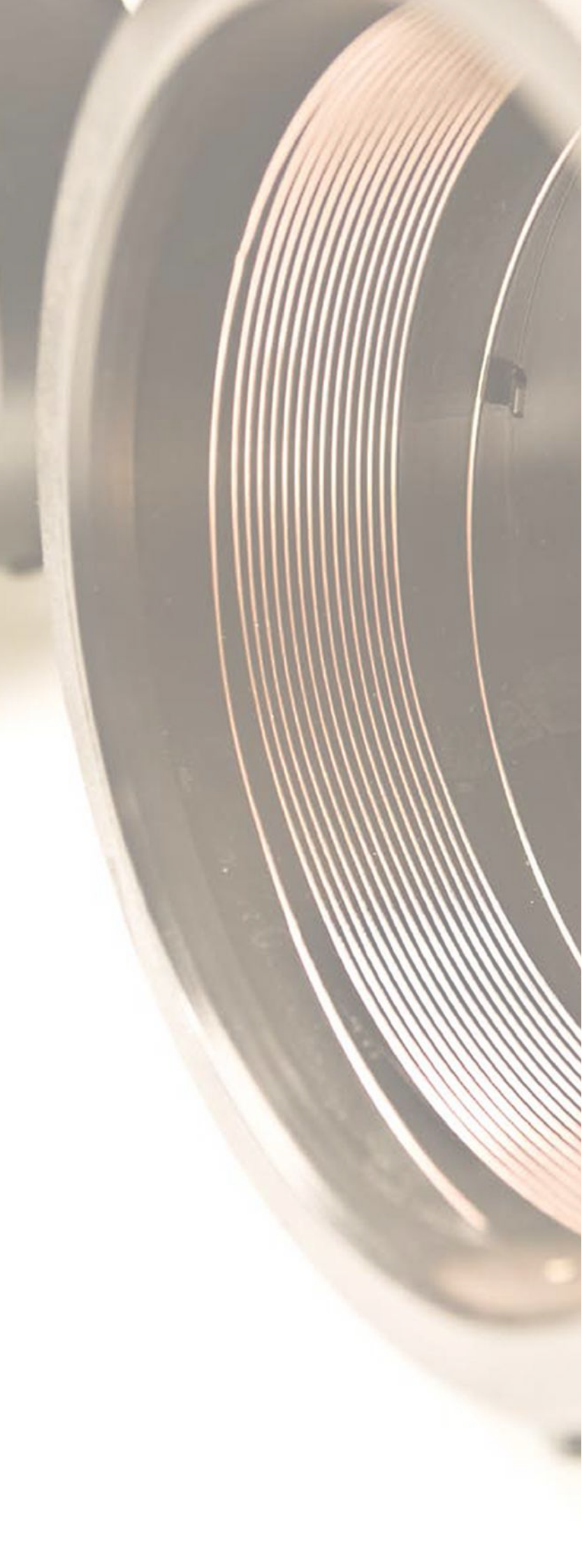

Accesorios electrosoldables PE100 RC SDR11 PN16

Con Declaración Ambiental de Producto (DAP)



Accesorios electrosoldables

Manguito electrosoldable PE100 RC SDR11 PFA/PN16

Descripción

- SDR mín: de Ø20 a Ø50 soldable con SDR 11 - 9 - 7,4.
de Ø63 a Ø800 soldable con SDR 17,6 - 17 - 13,6 - 11 - 9 - 7,4.
de Ø225 con código de barras de precalentamiento.
- Con retén extraíble hasta Ø200, sin retén para diámetros mayores.

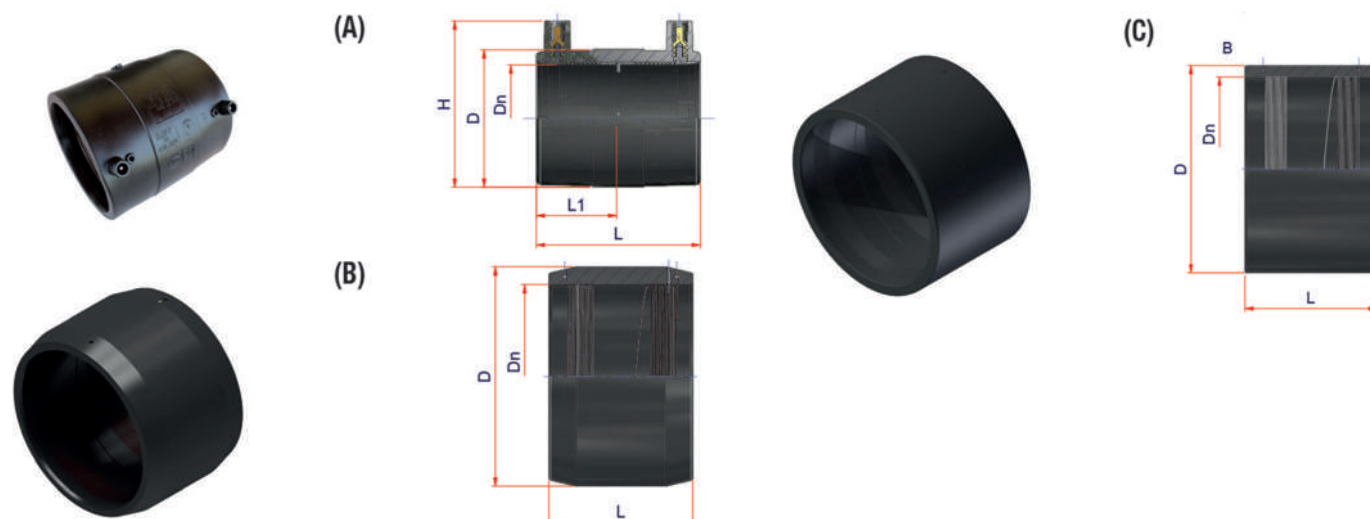

Referencia	Tipo	Ø (mm)	SDR mín.*	Dn (mm)	D (mm)	L1 (mm)	L (mm)	H (mm)	Uds. Caja	Precio (€/u.)
EME 20	A	20	11	20	33	20	33	53	120	3,16
EME 25	A	25	11	25	36	25	36	57	130	3,26
EME 32	A	32	11	32	46	32	46	65	80	3,35
EME 40	A	40	11	40	55	40	55	75	50	3,41
EME 50	A	50	11	50	67	50	67	86	40	5,01
EME 63	A	63	17,6	63	81	63	81	97	30	5,18
EME 75	A	75	17,6	75	98	75	98	114	24	8,74
EME 90	A	90	17,6	90	113	90	113	130	32	9,72
EME 110	A	110	17,6	110	132	110	132	144	22	11,54
EME 125	A	125	17,6	125	156	125	156	168	16	16,32
EME 140	A	140	17,6	140	168	140	168	181	45	21,65
EME 160	A	160	17,6	160	191	160	191	201	28	21,77
EME 180	A	180	17,6	180	215	180	215	224	22	38,08
EME 200	A	200	17,6	200	236	200	236	243	18	43,11
EME 225	A	225	17,6	225	268	225	268	272,5	48	65,74
EME 250	A	250	17,6	250	296	250	296	300	36	84,00
EME 280	A	280	17,6	280	338	280	338	-	21	117,37
EME 315	A	315	17,6	315	375	315	375	-	24	128,74
EME 355	B	355	17,6	355	425	355	425	-	12	Consultar
EME 400	B	400	17,6	400	482	400	482	-	9	Consultar
EME 450	B	450	17,6	450	542	450	542	-	6	Consultar
EME 500	B	500	17,6	500	602	500	602	-	4	Consultar
EME 560	C	560	17,6	560	670	560	670	-	3	Consultar
EME 630	C	630	17,6	630	750	630	750	-	2	Consultar
EME 710	C	710	17,6	710	855	710	855	-	1	Consultar
EME 800	C	800	17,6	800	970	800	970	-	1	Consultar
EME 900	C	900	17,6	900	-	900	-	-	1	Consultar
EME 1000	C	1000	17,6	1000	-	1000	-	-	1	Consultar

Accesorios electrosoldables

Codo electrosoldable a 90° PE100 RC SDR11 PFA/PN16

Descripción

-(*) SDR mín: de Ø20 a Ø40 soldable con SDR 11 - 9 - 7,4.
de Ø50 a Ø315 soldable con SDR 17,6 - 17 - 13,6 - 11 - 9 - 7,4.

-Tipo A y B monofilar.

-Tipo C bifilar.

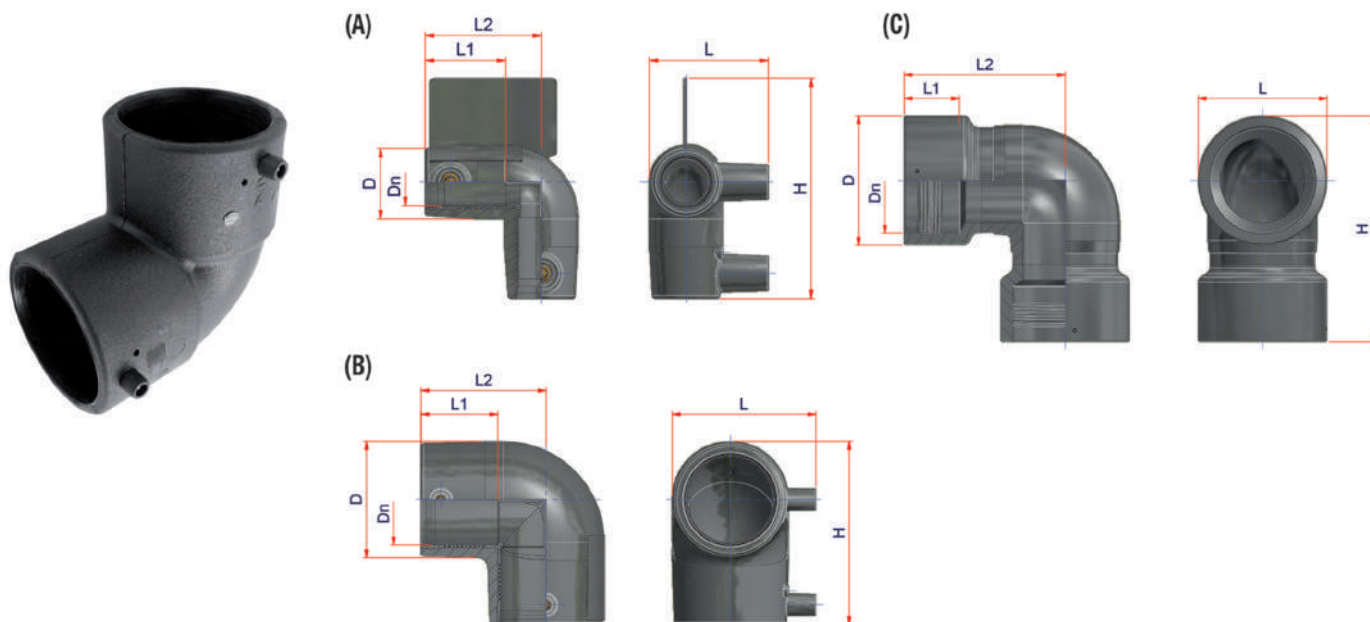

Referencia	Tipo	Ø (mm)	SDR mín.*	Dn (mm)	D (mm)	L1 (mm)	L2 (mm)	L (mm)	H (mm)	Uds. Caja	Precio (€/u.)
EGEM 20	A	20	11	20	32	34	50,5	52	95,5	80	9,49
EGEM 25	A	25	11	25	37	37	54	57	102	100	9,49
EGEM 32	B	32	11	32	45	34	57,5	64	80	80	8,48
EGEM 40	B	40	11	40	53	41	65	73	91,5	50	8,91
EGEM 50	B	50	17,6	50	65	48	77	84	109,5	30	13,36
EGEM 63	B	63	17,6	63	78	53	88	100	129	20	12,61
EGEM 75	B	75	17,6	75	90	58	97	110	142	12	22,35
EGEM 90	B	90	17,6	90	119	70	122	133	182	14	24,78
EGEM 110	B	110	17,6	110	139	83	144	164	214	10	35,58
EGEM 125	B	125	17,6	125	158	88	157,5	180	237	8	58,77
EGEM 160	B	160	17,6	160	192	90	173	208,5	269	12	98,55
EGEM 180	B	180	17,6	180	208	112	185	225	289	10	163,13
EGEM 200	B	200	17,6	200	242	100	213	253,5	320	5	263,98
EGE 225	C	225	17,6	225	274	124	337	274	474	4	441,43
EGE 250	C	250	17,6	250	308	132	385	308	539	8	564,29
EGE 315	C	315	17,6	315	380	155	422	380	612	2	958,93

Accesorios electrosoldables

Codo electrosoldable a 45° PE100 RC SDR11 PFA/PN16

Descripción

-(*) SDR mín: $\varnothing 32$ y $\varnothing 40$ soldable con SDR 11 - 9 - 7,4.
de $\varnothing 50$ a $\varnothing 315$ soldable con SDR 17,6 - 17 - 13,6 - 11 - 9 - 7,4

-Tipo A monofilar .

-Tipo B bifilar.

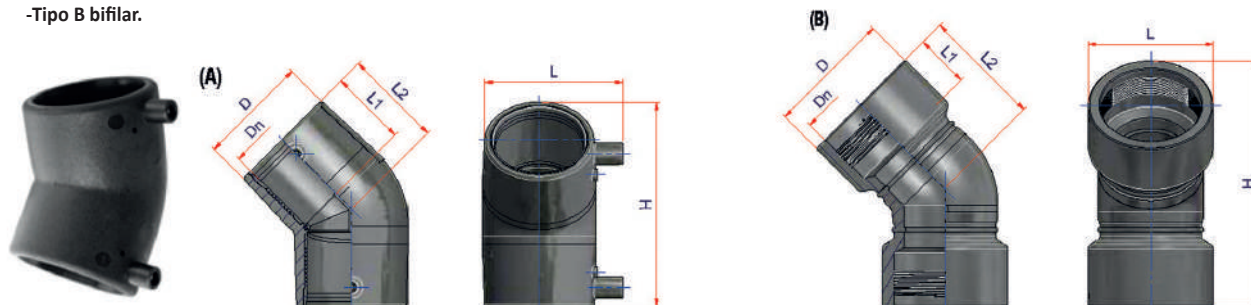

Referencia	Tipo	\varnothing (mm)	SDR mín.*	Dn (mm)	D (mm)	L1 (mm)	L2 (mm)	L (mm)	H (mm)	Uds. Caja	Precio (€/u.)
ECM032	A	32	11	32	45	36	46,5	64,5	94	80	9,20
ECM040	A	40	11	40	55	41	53,5	75	109	50	10,99
ECM050	A	50	17,6	50	65	48	62,5	83	128	34	15,58
ECM063	A	63	17,6	63	80	53	68	100	147	20	12,85
ECM075	A	75	17,6	75	95	60	81	113	169	14	24,85
ECM090	A	90	17,6	90	119	70	99	134	208	16	27,60
ECM110	A	110	17,6	110	137	83	114	161,5	241	12	39,63
ECM125	A	125	17,6	125	170	85	122	157	246	8	63,55
ECM160	A	160	17,6	160	192	90	134	208,5	296	12	105,22
ECM180	A	180	17,6	180	215	106	160	240	340	6	169,27
ECM200	A	200	17,6	200	242	97,5	167	250,5	368	6	273,24
ECE225	B	225	17,6	225	274	124	277	274	550	4	441,42
ECE250	B	250	17,6	250	308	132	292	308	600	9	564,29
ECE315	B	315	17,6	315	380	155	337	380	680	2	932,86

Codo electrosoldable a 30° PE100 RC SDR11 PFA/PN16

Descripción

-(*) SDR mín: soldable con SDR 17,6 - 17 - 13,6 - 11 - 9 - 7,4.

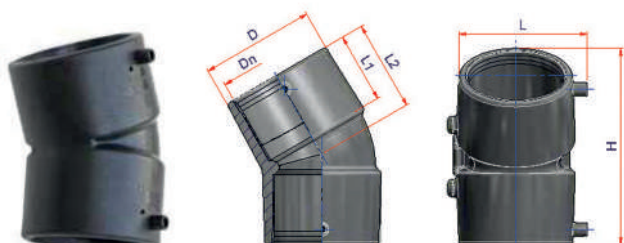

Referencia	\varnothing (mm)	SDR mín.*	Dn (mm)	D (mm)	L1 (mm)	L2 (mm)	L (mm)	H (mm)	Uds. Caja	Precio (€/u.)
ECM30090	90	17,6	90	119,2	70	93,6	134	209	20	36,02
ECM30110	110	17,6	110	134	83	107	154	233	12	55,96
ECM30125	125	17,6	125	159,4	88,6	114,5	172,5	264,5	8	62,39

Accesorios electrosoldables

Te electrosoldable PE100 RC SDR11 PFA/PN16

Descripción

- (*) SDR mín: de Ø20 a Ø63 soldable con SDR 11 - 9 - 7,4.
de Ø75 a Ø315 soldable con SDR 17,6 - 17 - 13,6 - 11 - 9 - 7,4.

-Tipo A monofilar con derivación inyectada.

-Tipo B bifilar con derivación inyectada.

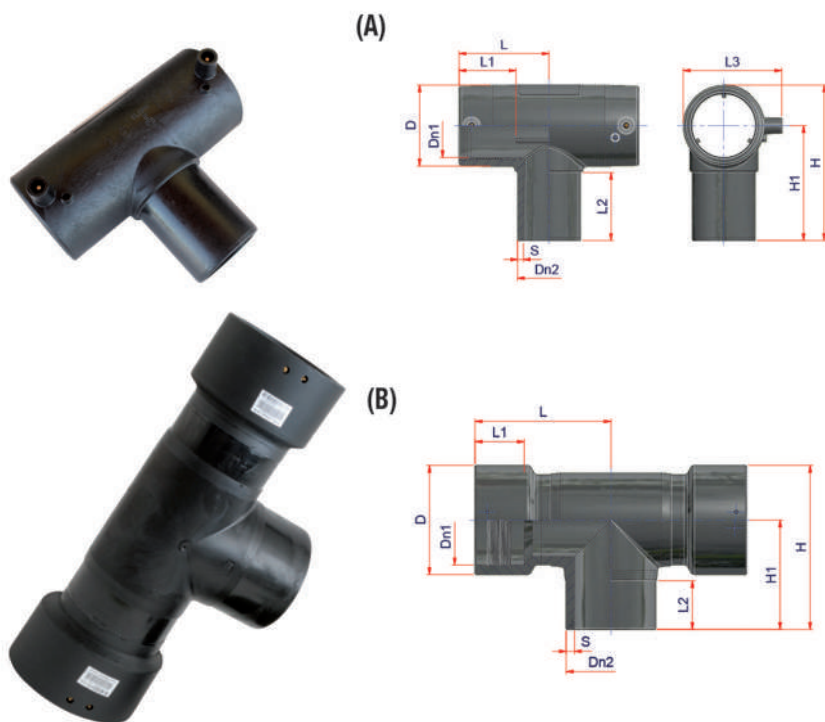

Referencia	Tipo	Ø (mm)	SDR mín.*	Dn1 (mm)	Dn2 (mm)	S (mm)	D (mm)	L1 (mm)	L2 (mm)	L3 (mm)	L (mm)	H1 (mm)	H (mm)	Uds. Caja	Precio (€/u.)
ETCE 020	A	20	11	20	20	3	32	37,5	46	52	45	66,5	83	100	11,28
ETCE 025	A	25	11	25	25	3	37	37,5	46	57	50	68,5	87	60	11,28
ETCE 032	A	32	11	32	32	3	44	37,5	47	64	55	75	96,5	50	11,28
ETCE 040	A	40	11	40	40	3,7	54	44	54	74	66,5	84	111	30	14,25
ETCE 050	A	50	11	50	50	4,6	65	46,5	61	85	76,5	100	133,5	20	15,88
ETCE 063	A	63	11	63	63	5,8	80	57	68	99	90	115	156	12	16,63
ETCE 075	A	75	17,6	75	75	6,8	95	58	72	112	98	130	178	20	25,53
ETCE 090 *	A	90	17,6	90	90	8,2	118	70	84	139,5	122	150	209	10	29,66
ETCE 110	A	110	17,6	110	110	10	139	83	88,5	156,5	144	177	247	7	48,03
ETCE 125	A	125	17,6	125	125	11,4	158	88	94	174	157,5	191,5	270	5	64,99
ETCE 160	A	160	17,6	160	160	14,6	190	87	105	201,5	151	208	303	1	107,81
ETCE 180	A	180	17,6	180	180	16,4	210	92	105	230	165	245	350	8	173,81
ETCE 200	A	200	17,6	200	200	18,2	240	115	116	-	311,5	258	388	4	369,62
ETCE 225	B	225	17,6	225	225	20,5	274	124	125	-	342	275	412	10	519,41
ETCE 250	B	250	17,6	250	250	22,7	308	120	135	-	377	305	459	5	705,36
ETCE 315	B	315	17,6	315	315	28,6	380	155	150	-	427	350	540	4	1.167,26

* Hasta finalización de existencias se proveerá accesorio con 3 bocas tipo hembra.

Accesorios electrosoldables

Te reducida electrosoldable PE100 RC SDR11 PFA/PN16

Descripción

-(*) SDR mín: Ø32 soldable con SDR 11 - 9 - 7,4.
de Ø110 soldable con SDR 17,6 - 17 - 13,6 - 11 - 9 - 7,4.

-Tipo A monofilar con derivación inyectada.

-Tipo B bifilar con derivación inyectada.

-Tipo C bifilar con derivación inyectada soldada.

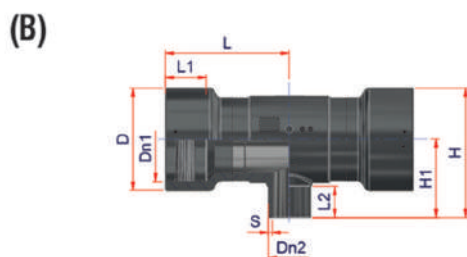
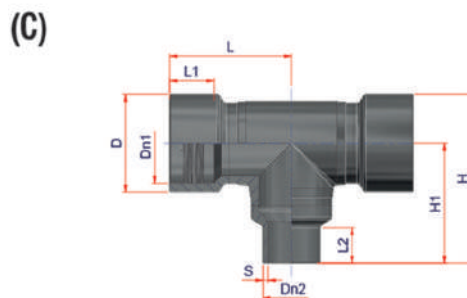
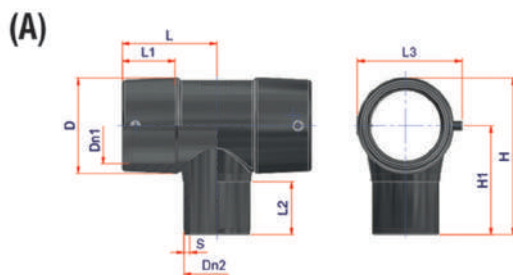

Referencia	Tipo	Ø (mm)	SDR mín.*	Dn1 (mm)	Dn2 (mm)	S (mm)	D (mm)	L1 (mm)	L2 (mm)	L3 (mm)	L (mm)	H1 (mm)	H (mm)	Uds. Caja	Precio (€/u.)
ETER3220	A	32-20	11	32	20	3,0	42	37,5	45	63,5	55	70	91	50	19,57
ETER1163	A	110-63	17,6	110	63	5,8	140	83	68,5	156,5	144	150	220	8	62,69
ETER1190	A	110-90	17,6	110	90	8,2	140	83	88,5	156,5	144	170	240	8	62,69
ETER1263	A	125-63	17,6	125	63	5,8	159	88	68,5	174	157,5	162	241,5	6	80,85
ETER1290	A	125-90	17,6	125	90	8,2	159	88	90	174	157,5	182	261,5	6	80,85
ETER1211	A	125-110	17,6	125	110	10,0	159	88	88,5	174	157,5	182	261,5	6	80,85
ETER1663	A	160-63	17,6	160	63	5,8	195	90	78,5	206	155	185	283	10	163,72
ETER1690	A	160-90	17,6	160	90	8,2	195	90	83,5	206	155	190	288	10	163,72
ETER1611	A	160-110	17,6	160	110	10,0	195	90	88,5	206	155	195	293	10	163,72
ETER1612	A	160-125	17,6	160	125	11,4	195	90	93,5	206	155	200	298	10	163,72
ETER1890	B	180-90	17,6	180	90	8,2	225	93,5	84	358	-	197	309,5	10	240,23
ETER1811	B	180-110	17,6	180	110	10,0	225	93,5	95	358	-	197	309,5	1	267,98
ETER1812	B	180-125	17,6	180	125	11,4	225	93,5	100	358	-	205	317,5	4	321,79
ETER1816	B	180-160	17,6	180	160	14,6	225	93,5	110	358	-	210	222,5	1	240,23
ETER2063	B	200-63	17,6	200	63	5,7	240	108	70	383	-	187	307	1	552,31
ETER2090	B	200-90	17,6	200	90	8,2	240	108	90	383	-	207	327	4	457,97
ETER2011	B	200-110	17,6	200	110	10,0	240	108	87	383	-	207	327	6	457,97
ETER2012	B	200-125	17,6	200	125	11,4	240	108	95	383	-	215	335	1	552,31
ETER2016	B	200-160	17,6	200	160	14,6	240	108	103	383	-	223	343	1	768,21
ETER2263	B	225-63	17,6	225	63	5,7	273,5	115	70	-	403	200	337	1	816,20
ETER2290	B	225-90	17,6	225	90	8,2	273,5	115	90	-	403	217	354	1	571,34
ETER2211	B	225-110	17,6	225	110	10,0	273,5	115	87	-	403	217	354	10	571,34
ETER2212	B	225-125	17,6	225	125	11,4	273,5	115	95	-	403	225	362	1	816,20
ETER2216	B	225-160	17,6	225	160	14,6	273,5	115	103	-	403	235	372	10	705,36
ETER2218	B	225-180	17,6	225	180	16,4	273,5	115	110	-	403	235	372	1	816,20
ETER2590	B	250-90	17,6	250	90	8,2	308	125	90	-	438	232	386	1	705,36
ETER2511	B	250-110	17,6	250	110	10,0	308	125	116	-	438	258	412	1	705,36
ETER2512	B	250-125	17,6	250	125	11,4	308	125	95	-	438	237	391	1	1.108,43
ETER2516	B	250-160	17,6	250	160	14,6	308	125	105	-	438	247	401	1	705,36
ETER2518	C	250-180	17,6	250	180	16,4	308	125	103	-	405	360	514	3	1.108,43
ETER2520	B	250-200	17,6	250	200	18,2	308	125	116	-	438	258	412	1	1.108,43

Accesorios electrosoldables

Tapón electrosoldable PE100 RC SDR11 PFA/PN16

Descripción

-(*) SDR mín: de Ø20 a Ø50 soldable con SDR 11 - 9 - 7,4.
de Ø63 a Ø315 soldable con SDR 17,6 - 17 - 13,6 - 11 - 9 - 7,4.

-Tipos A y B una pieza (*).

-Tipo C compuesto de dos piezas (ECAL+EME).

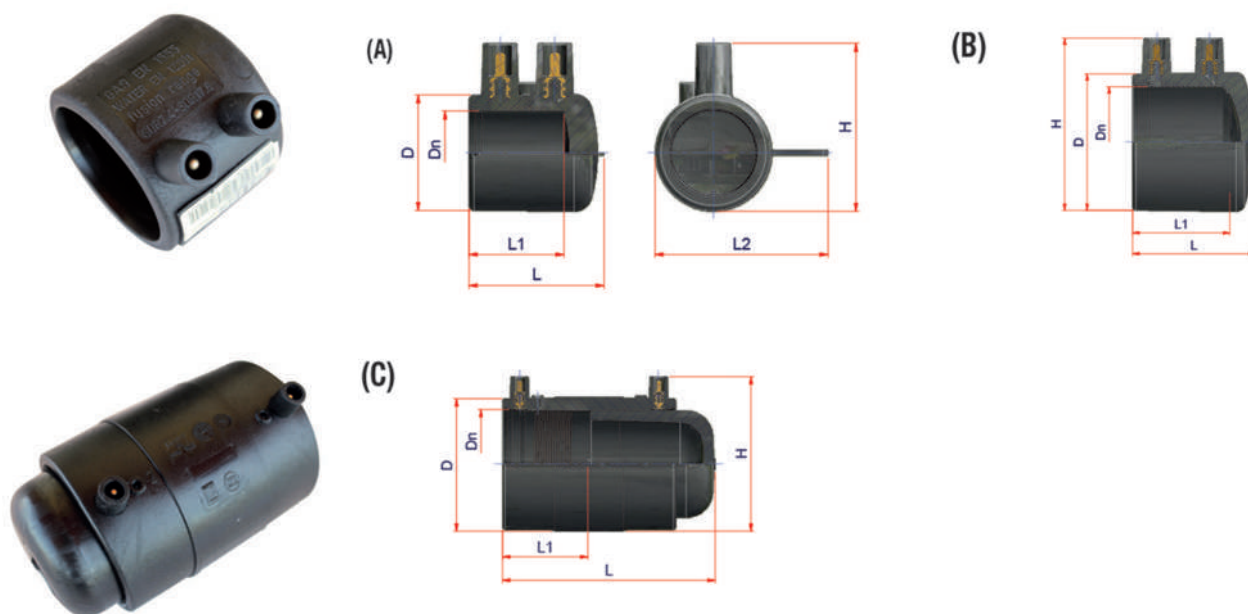

Referencia	Tipo	Ø (mm)	SDR mín.*	Dn (mm)	D (mm)	L1 (mm)	L2 (mm)	L (mm)	H (mm)	Uds. Caja	Precio (€/u.)
ECALE020	C	20	11	20	33	34	-	91	53	130	6,24
ECALE025	A	25	11	25	36	39,5	62,5	54	56	150	6,38
ECALE032	A	32	11	32	45	36	67	52	65	100	7,57
ECALE040	A	40	11	40	53	42	60	62,5	76,5	80	8,30
ECALE050	A	50	11	50	68	46,5	96,5	61	88	60	11,84
ECALE063	B	63	17,6	63	80,5	52	-	71	101	40	13,20
ECALE075	C	75	17,6	75	98	61	-	159	114	20	23,74
ECALE090	C	90	17,6	90	113	72	-	180	130	25	25,89
ECALE110	C	110	17,6	110	136	76,5	-	195	144	15	33,94
ECALE125	C	125	17,6	125	156	82	-	210	168	8	47,50
ECALE140	C	140	17,6	140	168	84	-	215	181	8	74,21
ECALE160	C	160	17,6	160	191	87	-	230	201	6	64,20
ECALE180	C	180	17,6	180	215	88	-	220	224	18	122,62
ECALE200	C	200	17,6	200	236	92	-	265	243	7	116,54
ECALE225	C	225	17,6	225	272	104	-	253	274	1	184,78
ECALE250	C	250	17,6	250	296	106	-	256	300	2	235,75
ECALE280	C	280	17,6	280	355	-	-	227	355	1	345,89
ECALE315	C	315	17,6	315	400	-	-	328	400	2	474,91

Accesorios electrosoldables

Manguito electrosoldable PE100 RC SDR17 PFA/PN10

Descripción

- (*) SDR mín: $\varnothing 90 \div 200$ soldable con SDR 17,6 - 17 - 13,6 - 11.
- (*) SDR mín: $\varnothing 225 \div 1200$ soldable con SDR 21 - 17,6 - 17 - 13,6 - 11.
- (*) SDR mín: de $\varnothing 225$ con código de barras de precalentamiento.
- Con retén extraíble hasta $\varnothing 200$, sin retén para diámetros mayores.

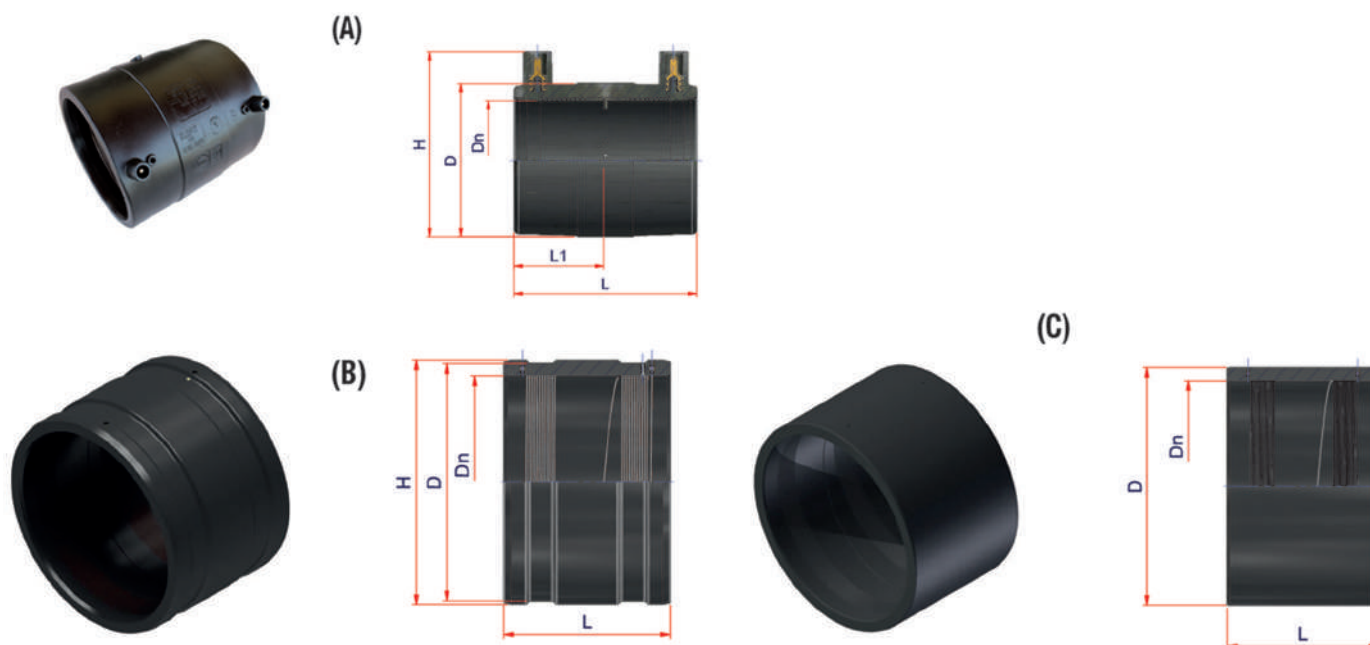

Referencia	Tipo	\varnothing (mm)	SDR mín.*	Dn (mm)	D (mm)	L1 (mm)	L (mm)	H (mm)	Uds. Caja	Precio (€/u.)
DME90	A	90	17,6	90	113	72	146	130	30	13,75
DME110	A	110	17,6	110	136	76,5	155	144	22	14,18
DME125	A	125	17,6	125	156	82	166	168	16	19,74
DME140	A	140	21	140	168	84	170	181	39	24,44
DME160	A	160	17,6	160	181	87	175	197	36	26,09
DME180	A	180	17,6	181	215	88	177	224	22	39,24
DME200	A	200	21	200	226	92	185	237	20	46,61
DME225	A	225	21	225	268	108	231,5	272,5	48	67,68
DME250	A	250	26	250	296	106	212	300	36	73,55
DME280	B	280	26	280	318	-	270	332	21	119,47
DME315	A	315	26	315	359	120	251	361	24	133,18
DME355	B	355	26	355	398	-	300	412	12	Consultar
DME400	B	400	26	400	455	-	315	469	9	Consultar
DME450	B	450	26	450	512	-	340	526	6	Consultar
DME500	B	500	26	500	568	-	380	582	4	Consultar
DME560	C	560	21	560	630	-	400	-	3	Consultar
DME630	C	630	21	630	710	-	440	-	3	Consultar
DME710	C	710	21	710	810	-	432	-	2	Consultar
DME800	C	800	21	800	910	-	452	-	1	Consultar
DME900	C	900	21	900	1010	-	470	-	1	Consultar
DME1000	C	1000	21	1000	1130	-	490	-	1	Consultar
DME1200	C	1200	21	1200	1345	-	500	-	1	Consultar

Accesorios electrosoldables

Reducción electrosoldable PE100 RC SDR11 PFA/PN16

Descripción

- (*) SDR mín: de Ø20 a Ø50 soldable con SDR 11 - 9 - 7,4.
- (*) SDR mín: de Ø63 a Ø315 soldable con SDR 17,6 - 17 - 13,6 - 11 - 9 - 7,4.
- Tipo A y B monofilar.
- Tipo C bifilar.

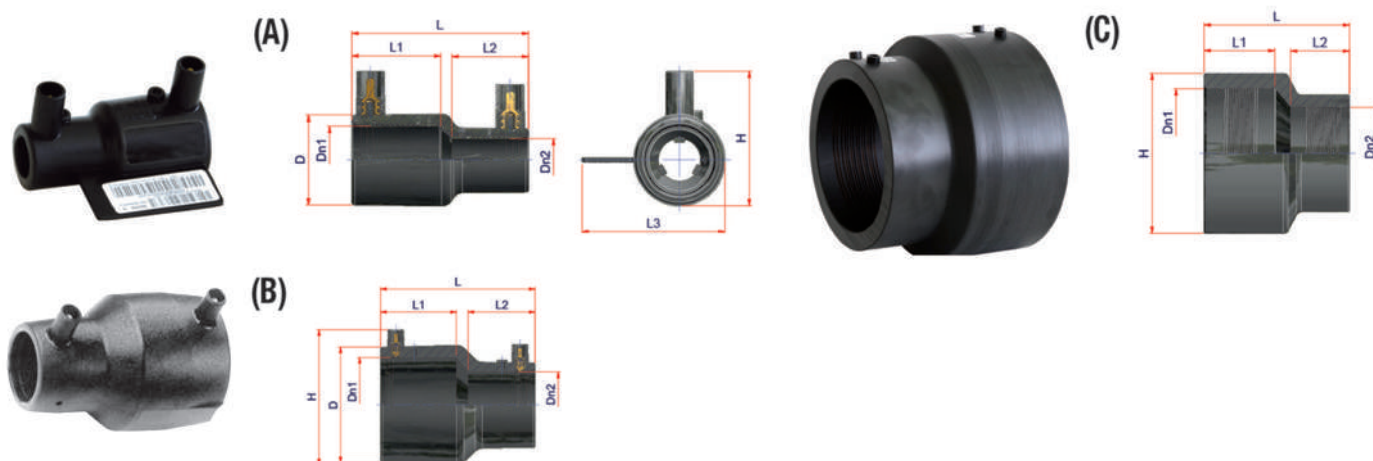

Referencia	Tipo	Ø (mm)	SDR mín.*	Dn1 (mm)	Dn2 (mm)	D (mm)	L1 (mm)	L2 (mm)	L3 (mm)	L (mm)	H (mm)	Uds. Caja	Precio (€/u.)
ERDE 2520	A	25-20	11	25	20	36	40	37	62	85	57	20	6,83
ERDE 3220	A	32-20	11	32	20	43	43	37	69	85	64,5	30	6,83
ERDE 3225	A	32-25	11	32	25	44	39,5	39,5	70	84,5	64,5	20	6,83
ERDE 4020	A	40-20	11	40	20	52,5	48	40	79,5	95	74	20	13,65
ERDE 4032	B	40-32	11	40	32	55	47	42	-	95	74	20	10,10
ERDE 5032	B	50-32	11	50	32	64	49,5	41,5	-	100	85	20	11,43
ERDE 5040	B	50-40	11	50	40	64	49,5	47,5	-	103	85	10	11,57
ERDE 6332	B	63-32	11	63	32	81,5	55,5	42	-	118	99	18	13,36
ERDE 6340	B	63-40	11	63	40	81,5	55	45	-	118	99	18	13,36
ERDE 6350	B	63-50	11	63	50	81,5	55,5	50	-	118	99	18	13,36
ERDE 7563	B	75-63	11	75	63	97	60	57	-	125	114	12	21,27
ERDE 9050	B	90-50	11	90	50	117	72	49	-	142	133,5	30	21,74
ERDE 9063	B	90-63	17,6	90	63	115	68	62	-	150	131	30	21,55
ERDE 9075	B	90-75	17,6	90	75	116	73,5	65	-	152,5	131	32	28,37
ERDE 1163	B	110-63	17,6	110	63	135	72,5	63	-	160	150,5	24	29,35
ERDE 1190	B	110-90	17,6	110	90	135	73	68,5	-	158	150,5	24	29,35
ERDE 1263	B	125-63	17,6	125	63	150	76	65	-	162,5	167	20	47,50
ERDE 1290	B	125-90	17,6	125	90	150	80	70	-	160	167	16	47,50
ERDE 1211	B	125-110	17,6	125	110	156	70	71,5	-	161	167	16	47,50
ERDE 1690	B	160-90	17,6	160	90	192	81	72	-	177	207	12	70,87
ERDE 1611	B	160-110	17,6	160	110	192	81	77	-	182	207	12	70,87
ERDE 1612	B	160-125	17,6	160	125	186	76	73,5	-	179	201	8	70,87
ERDE 2016	C	200-160	17,6	200	160	-	113	102	-	225	250	48	318,37
ERDE 2018	C	200-180	17,6	200	180	-	113	112	-	235	250	28	318,37
ERDE 2216	C	225-160	17,6	225	160	-	124	103	-	255	278	44	319,01
ERDE 2218	C	225-180	17,6	225	180	-	124	112	-	255	278	22	358,68
ERDE 2220	C	225-200	17,6	225	200	-	124	113	-	255	278	22	358,68
ERDE 2518	C	250-180	17,6	250	180	-	124	113	-	255	278	24	404,76
ERDE 250200	C	250-200	17,6	250	200	-	119	98	-	242	305	24	450,80
ERDE 2522	C	250-225	17,6	250	225	-	135	125	-	275	308	24	525,94
ERDE 3125	C	315-250	17,6	315	250	-	120	120	-	270	390	18	645,77
ERDE 3128	C	315-280	17,6	315	280	-	155	130	-	295	390	18	645,77



Accesorios de transición PE100 RC SDR11 PN16

Con Declaración Ambiental de Producto (DAP)



Accesorios de transición - Terminales roscados

Accesorios de transición PE/Latón con racor loco PE100 RC SDR11 PFA/PN16

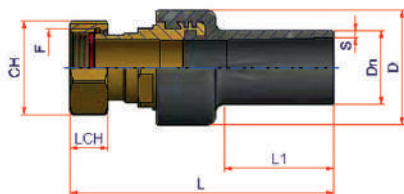

Referencia	D x R (mm)	Dn (mm)	S (mm)	L1 (mm)	F (mm)	L (mm)	D (mm)	CH (mm)	LCH (mm)	Uds. Caja	Precio (€/u.)
EBD 2012	20x1/2"	20	3	44	1/2"	109	36	26	16	50	21,59
EBD 2512	25x1/2"	25	3	46	1/2"	109	36	26	16	40	21,59
EBD 2534	25x3/4"	25	3	44	3/4"	112	41	30	16	40	21,59
EBD 3234	32x3/4"	32	3	51	3/4"	116	41	30	16	25	24,83
EBD 321	32x1"	32	3	48	1"	118	50	37	17	30	24,83
EBD 401	40x1"	40	3,7	55	1"	123	50	37	17	15	30,42
EBD 40114	40x1 1/4"	40	3,7	53	1 1/4"	135	63	48	21	12	30,42
EBD 50112	50x1 1/2"	50	4,6	61	1 1/2"	145	70	54	22	10	33,07
EBD 631	63x1"	63	5,8	77	1"	143	63	37	17	12	45,63
EBD 632	63x2"	63	5,8	69	2"	162	83	66	25	7	45,63

ATENCIÓN: Junta elástica solo para agua.

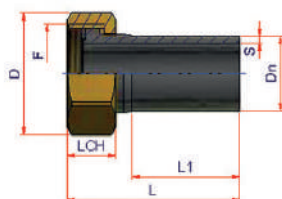
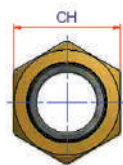

Referencia	D x R (mm)	Dn (mm)	S (mm)	L1 (mm)	F (mm)	L (mm)	D (mm)	CH (mm)	LCH (mm)	Uds. Caja	Precio (€/u.)
EBD 251	25x1"	25	3	42	1"	69	42	37	18	60	21,59
EBD 32114	32x1 1/4"	32	3	46	1 1/4"	75	52,5	46	21	40	24,83
EBD 40112	40x1 1/2"	40	3,7	51	1 1/2"	84	56,5	52	22	20	30,42
EBD 502	50x2"	50	4,6	57	2"	93	71,5	66	25	15	33,07
EBD 63212	63x2 1/2"	63	5,8	65	2 1/2"	105	86	80	30	10	45,63

ATENCIÓN: Junta elástica solo para agua.

Accesorios de transición - Terminales roscados

Accesorios de transición PE/Latón terminal recto roscado macho PE100 RC SDR11 PFA/PN16

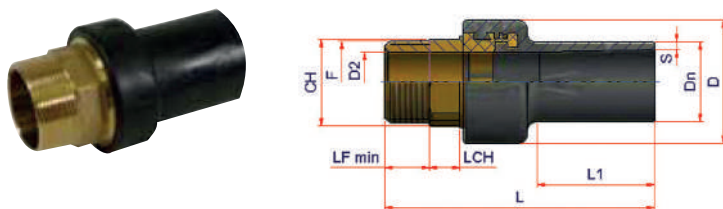

Referencia	D x R (mm)	Dn (mm)	S (mm)	L1 (mm)	D2 (mm)	F (mm)	LF min. (mm)	L (mm)	D (mm)	CH (mm)	LCH (mm)	Uds. Caja	Precio (€/u.)
ERFM 2012	20x1/2"	20	3	44	13	1/2"	13,2	100	36	22	11	50	15,87
ERFM 2534	25x3/4"	25	3	44	18	3/4"	14,5	103	41	27	12	50	18,70
ERFM 3234	32x3/4"	32	3	47	18	3/4"	14,5	103	41	27	12	30	21,02
ERFM 321	32x1"	32	3	47	24	1"	16,8	110	50	34	13	30	21,14
ERFM 401	40x1"	40	3,7	54	24	1"	16,8	115	50	34	13	25	32,46
ERFM 40114	40x1 1/4"	40	3,7	53	31	1 1/4"	19,1	124	63	42	15	20	34,30
ERFM 50112	50x1 1/2"	50	4,6	61	38	1 1/2"	19,1	131	70	50	15	14	32,52
ERFM 502	50x2"	50	4,6	61	38	2"	23,4	140	83	60	18	8	51,43
ERFM 632	63x2"	63	5,8	69	49	2"	23,4	147	83	60	18	7	43,97
ERFM 75212	75x2 1/2"	75	6,8	76	60	2 1/2"	26,7	163	107	80	20	7	80,52
ERFM 903	90x3"	90	8,2	87	71	3"	29,8	183	118	90	23	4	105,94
ERFM 1104	110x4"	110	10	85	90	4"	35,8	202	153	115	30	2	127,84
ERFM 1254	125x4"	125	11,4	95	99	4"	35,8	214	153	115	30	2	132,24

Accesorios de transición PE/Latón terminal recto roscado hembra PE100 RC SDR11 PFA/PN16

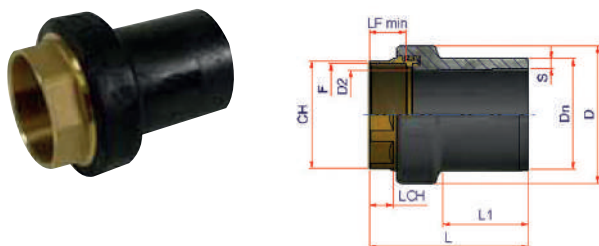

Referencia	D x R (mm)	Dn (mm)	S (mm)	L1 (mm)	D2 (mm)	F (mm)	LF min. (mm)	L (mm)	D (mm)	CH (mm)	LCH (mm)	Uds. Caja	Precio (€/u.)
ERFF 2012	20x1/2"	20	3	44	13	1/2"	17	84	37	25	11	50	15,87
ERFF 2534	25x3/4"	25	3	44	18	3/4"	18	86	41	30	12	60	18,38
ERFF 321	32x1"	32	3	47	24	1"	21	91	50	38	13	30	19,47
ERFF 401	40x1"	40	3,7	53	24	1"	21	95	50	38	13	25	28,66
ERFF 40114	40x1 1/4"	40	3,7	53	31	1 1/4"	21,4	100	64	46	15	20	30,24
ERFF 50112	50x1 1/2"	50	4,6	61	38	1 1/2"	19	108	70	55	15	10	36,74
ERFF 632	63x2"	63	5,8	69	49	2"	23,7	122	84	65	20	9	47,99
ERFF 75212	75x2 1/2"	75	6,8	76	60	2 1/2"	30,2	138	107	80	25	9	84,49
ERFF 903	90x3"	90	8,2	87	71	3"	33,3	153	119	95	24	4	105,94
ERFF 1104	110x4"	110	10	85	90	4"	39,3	165	152	120	30	2	127,84
ERFF 1254	125x4"	125	11,4	95	99	4"	39,3	177	153	120	30	2	132,24

Accesorios de transición - Terminales roscados

Accesorios de transición PE/Hierro fundido 3 piezas terminal recto roscado hembra
PE100 RC SDR11 PFA/PN16

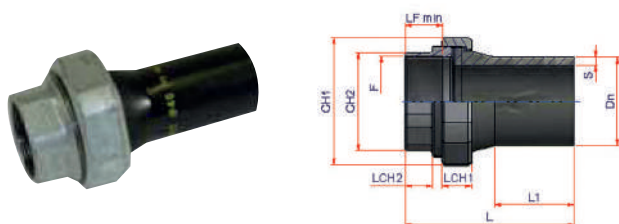

Referencia	D x R (mm)	Dn (mm)	S (mm)	L1 (mm)	D2 (mm)	F (mm)	LF min. (mm)	L (mm)	CH1 (mm)	LCH1 (mm)	CH2 (mm)	LCH2 (mm)	Uds. Caja	Precio (€/u.)
ERPAG 25	25x3/4"	25	3	42	13	3/4"	18	107	50	20	31	14	30	23,17
ERPAG 32	32x1"	32	3	45	18	1"	21	107	55	22	38	16	20	25,55
ERPAG 40	40x1 1/4"	40	3,7	65	18	1 1/4"	21,4	129	69	24	48	17	10	31,95
ERPAG 50	50x1 1/2"	50	4,6	66,5	24	1 1/2"	19	132	73	25	53	20	10	36,74
ERPAG 63	63x2"	63	5,8	75	49	2"	23,7	157	89	27	65	24	6	51,11
ERPAG 75	75x2 1/2"	75	6,8	86	60	2 1/2"	30,2	168	110	30	83	27	6	82,01
ERPAG 90	90x3"	90	8,2	100	71	3"	33,3	203	127	31	95	30	4	105,15
ERPAG 110	110x4"	110	10	98,5	90	3"	39,3	210	150	37	124	32	2	261,04
ERPAG 125	125x4"	125	11,4	117	99	4"	39,3	235	150	37	124	32	1	276,75

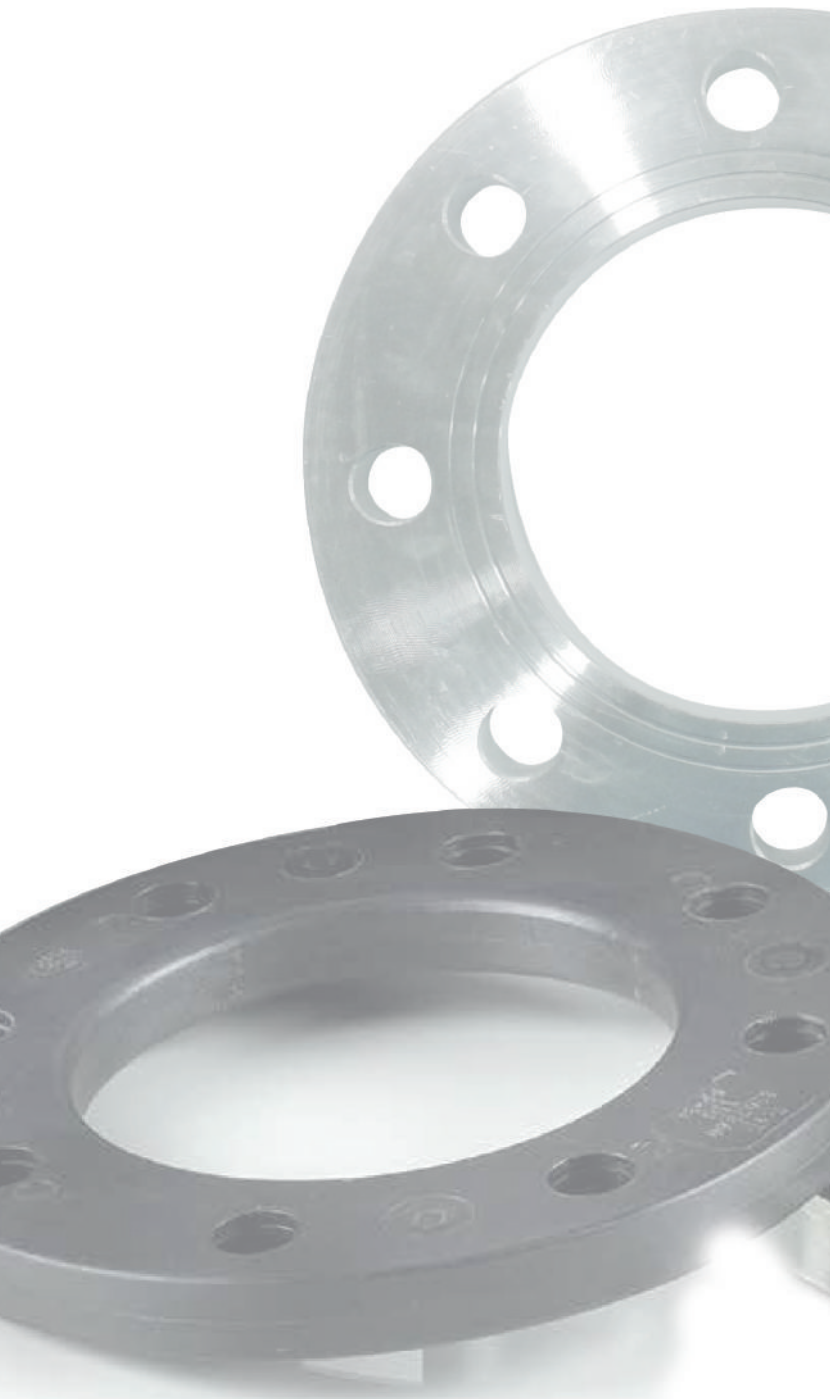

Bridas

Con Declaración Ambiental de Producto (DAP)



Portabridas y bridas

Brida de acero galvanizado revestimiento PP

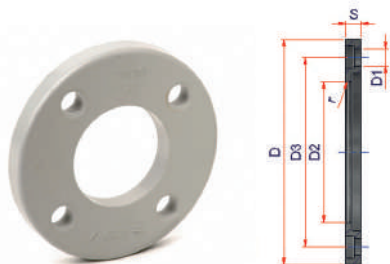

Referencia	PN	Ø Tubería PE (mm)	DN	Ø Exterior brida (mm)	Espesor Brida (mm)	Ø Interior brida (mm)	Distancia agujeros (mm)	Ø agujeros (mm)	Nº agujeros	Norma	Uds. Caja	Precio (€/u.)
E7159PP	10-16	25	20	108	14	34	75	14	4	DIN 2576	1	13,93
E7160PP	10-16	32	25	115	16	42	85	14	4	DIN 2576	1	17,92
E7161PP	10-16	40	32	140	18	51	100	18	4	DIN 2576	1	24,44
E7162PP	10-16	50	40	150	18	62	110	18	4	DIN 2576	1	28,07
E7163PP	10-16	63	50	165	18	78	125	18	4	DIN 2576	1	33,51
E7164PP	10-16	75	65	186	18	92	145	18	4	DIN 2576	1	39,53
E7165PP	10-16	90	80	202	20	108	160	18	8	DIN 2576	1	51,16
E7166PP	10-16	110	100	220	20	128	180	18	8	DIN 2576	1	64,90
E7167PP	10-16	125	100	220	20	135	180	18	8	DIN 2576	1	69,50
E7168PP	10-16	140	125	250	24	158	210	18	8	DIN 2576	1	83,72
E7169PP	10-16	160	150	285	23	178	240	22	8	DIN 2576	1	111,62
E7170PP	10-16	180	150	285	23	190	240	22	8	DIN 2576	1	111,60
E7171PP	10	200-225	200	340	25	235/238	295	22	8	DIN 2576	1	164,88
E7172PP	10	250	200	409	30	288	350	22	12	DIN 2576	1	213,97
E7173PP	10	280	250	409	30	294	350	22	12	DIN 2576	1	195,33
E7174PP	10	315	300	463	34	338	400	23	12	DIN 2576	1	296,50
E7175PP	10	355	350	515	42	376	460	22,5	16	DIN 2576	1	Consultar
E7176PP	10	400	400	574	46	430	515	26	16	DIN 2576	1	Consultar

Portabridas y bridas

Bridas de acero galvanizado

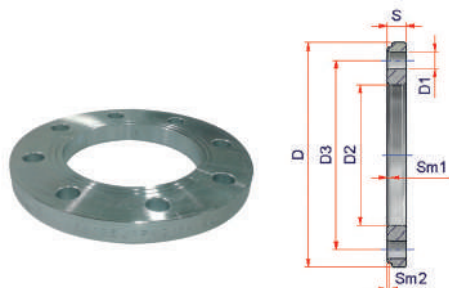

Referencia	PN	Ø Tubería PE (mm)	DN	Ø Exterior brida (mm)	Espesor Brida (mm)	Ø Interior brida (mm)	Distancia agujeros (mm)	Ø agujeros (mm)	Nº agujeros	Tornillo	Norma	Uds. Caja	Precio (€/u.)
E7159A	10-16	25	20	105	16	34	75	14	4	M12	DIN 2576	1	11,44
E7160A	10-16	32	25	115	16	43	85	14	4	M12	DIN 2576	1	12,19
E7161A	10-16	40	32	140	16	51	100	18	4	M16	DIN 2576	1	17,86
E7162A	10-16	50	40	150	16	62	110	18	4	M16	DIN 2576	1	21,93
E7163A	10-16	63	50	165	18	78	125	18	4	M16	DIN 2576	1	23,50
E7164A	10-16	75	65	185	18	92	145	18	4	M16	DIN 2576	1	32,73
E7165A	10-16	90	80	200	20	109	160	18	8	M16	DIN 2576	1	35,83
E7166A	10-16	110	100	220	20	128	180	18	8	M16	DIN 2576	1	43,79
E7167A	10-16	125	100	220	20	135	180	18	8	M16	DIN 2576	1	37,97
E7168A	10-16	140	125	250	22	158	210	18	8	M16	DIN 2576	1	57,48
E7169A	10-16	160	150	285	22	178	240	22	8	M20	DIN 2576	1	69,46
E7170A	10-16	180	150	285	22	188	240	22	8	M20	DIN 2576	1	63,79
E7171A	10	200	200	340	24	235	295	22	8	M20	DIN 2576	1	96,19
E7171/16A	16	200	200	340	24	235	295	22	12	M20	DIN 2502	1	80,26
E7172A	10	250	250	395	26	288	350	22	12	M20	DIN 2576	1	120,46
E7172/16A	16	250	250	405	26	288	355	26	12	M24	DIN 2502	1	118,34
E7173A	10	280	250	395	26	294	350	22	12	M20	DIN 2576	1	111,00
E7173/16A	16	280	250	405	26	294	355	26	12	M24	DIN 2502	1	113,68
E7174A	10	315	300	445	26	338	400	22	12	M20	DIN 2576	1	175,71
E7174/16A	16	315	300	460	28	338	410	26	12	M24	DIN 2502	1	159,94
E7175A	10	355	350	505	28	376	460	22	16	M20	DIN 2576	1	Consultar
E7175/16A	16	355	350	520	30	376	470	26	16	M24	DIN 2502	1	Consultar
E7176A	10	400	400	565	32	430	515	26	16	M24	DIN 2576	1	Consultar
E7176/16A	16	400	400	580	32	430	525	30	16	M27	DIN 2502	1	Consultar

Portabridas y bridas

Brida de acero galvanizado revestimiento PP Norma ANSI

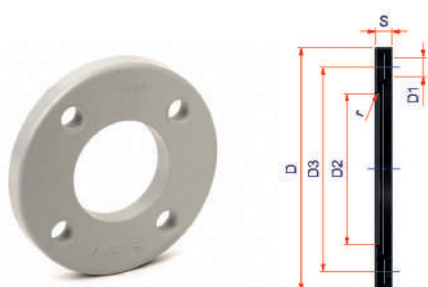

Referencia	PN	Ø Tubería PE (mm)	DN	Ø Exterior brida (mm)	Espesor Brida (mm)	Ø Interior brida (mm)	Distancia agujeros (mm)	Ø agujeros (mm)	Norma	Uds. Caja	Precio (€/u.)
E7159AN	10 – 16	25	20	102	12	34	69,85	16	ANSI	1	10,63
E7160AN	10 – 16	32	25	114	16	42	79,25	16	ANSI	1	13,76
E7161AN	10 – 16	40	32	130	16	51	88,9	16	ANSI	1	17,38
E7162AN	10 – 16	50	40	133	18	62	98,55	16	ANSI	1	20,28
E7163AN	10 – 16	63	50	162	18	78	120,65	20	ANSI	1	25,64
E7164AN	10 – 16	75	65	184	18	92	139,7	20	ANSI	1	28,90
E7165AN	10 – 16	90	80	194	18	111	152,4	20	ANSI	1	33,84
E7166AN	10 – 16	110	100	229	18	133	190,5	20	ANSI	1	40,18
E7167AN	10 – 16	125	100	229	18	133	190,5	20	ANSI	1	40,18
E7169AN	10 – 16	160	150	283	24	178	241,3	22	ANSI	1	70,90
E7171AN	10	200-225	200	345	24	236	298,45	22	ANSI	1	101,09
E7172AN	10	250	200	412	26	288	361,95	25	ANSI	1	161,28
E7174AN	10	315	300	487	32	338	431,8	25	ANSI	1	202,76

Portabridas y bridas

Brida de aluminio

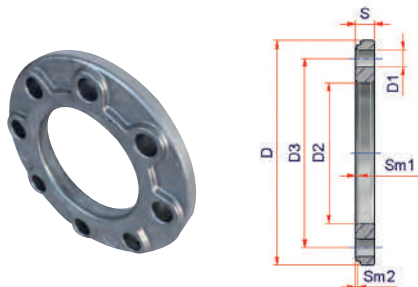

Referencia	Ø Tubería PEAD (mm)	Ø Interior brida (mm)	Ø Exterior brida (mm)	Nº agujeros	Distancia agujeros (mm)	Ø agujeros (mm)	Para conexión con válvula DN	PN	Norma	Uds. Caja	Precio (€/u.)
E7160	32	45	115	4	85	14	DN25 1"	16	DIN 2642 UNI 2223	1	16,73
E7161	40	51	140	4	100	18	DN32 1 1/4"	16	DIN 2642 UNI 2223	1	29,20
E7162	50	62	150	4	110	18	DN40 1 1/2"	16	DIN 2642 UNI 2223	1	31,56
E7163	63	78	165	4	125	18	DN50 2"	16	DIN 2642 UNI 2223	1	35,57
E7164	75	92	185	4	145	18	DN65 2 1/2"	16	DIN 2642 UNI 2223	1	47,94
E7165	90	108	200	8	160	18	DN80 3"	16	DIN 2642 UNI 2223	1	54,43
E7166	110	128	220	8	180	18	DN100 4"	16	DIN 2642 UNI 2223	1	58,01
E7167	125	133	220	8	180	18	DN100 4"	16	DIN 2642 UNI 2223	1	61,07
E7168	140	158	250	8	210	18	DN125 5"	16	DIN 2642 UNI 2223	1	78,02
E7169	160	178	285	8	240	22	DN150 6"	16	DIN 2642 UNI 2223	1	94,62
E7170	180	188	285	8	240	22	DN150 6"	16	DIN 2642 UNI 2223	1	118,11
E7171	200/225	238	340	8	295	22	DN200 8"	10	DIN 2642 UNI 2223	1	150,03
E7172	250	288	395	8	350	22	DN250 10"	10	DIN 2642 UNI 2223	1	199,04
E7172/16	250	288	395	12	355	22	DN250 10"	16	DIN 2642 UNI 2223	1	219,01
E7173	280	294	395	8	350	22	DN250 10"	10	DIN 2642 UNI 2223	1	199,04
E7173/16	280	294	395	12	350	22	DN250 10"	16	DIN 2642 UNI 2223	1	219,01
E7174	315	338	445	8	400	22	DN300 12"	10	DIN 2642 UNI 2223	1	330,41
E7174/16	315	338	445	12	400	22	DN300 12"	16	DIN 2642 UNI 2223	1	368,98

Portabridas y bridas

Junta plana de caucho sintético EPDM

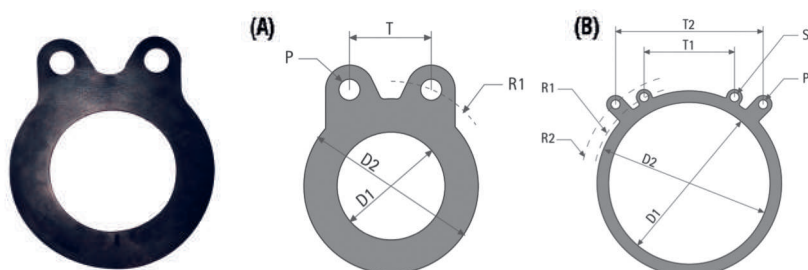

Referencia	Ø PE (mm)	Tipo	DN goma (mm)	D1 (mm)	D2 (mm)	Sp (mm)	Ø P (mm)	R1 (mm)	R2 (mm)	Ø S (mm)	T (mm)	T1 (mm)	T2 (mm)	Uds. Caja	Precio (€/u.)
EGR 63	63	A	50	60	96	3	15	61	-	-	87	-	-	1	2,44
EGR 75	75	A	65	77	121	3	18	71	-	-	93	-	-	1	2,44
EGR 90	90	A	80	80	130	3	16	78	-	-	61	-	-	1	2,78
EGR 110	110	A	100	100	154	3	16	88	-	-	68	-	-	1	3,26
EGR 125	125	A	100	100	154	3	16	88	-	-	68	-	-	1	3,39
EGR 140	140	A	125	125	183	3	16	107	-	-	81	-	-	1	5,84
EGR 160	160	A	150	150	208	3	20	118	-	-	91	-	-	1	6,29
EGR 180	180	A	150	150	208	3	20	118	-	-	91	-	-	1	6,29
EGR 200	200	A	200	200	263	3	20	146	-	-	75	-	-	1	10,08
EGR 225	225	A	200	200	263	3	20	146	-	-	75	-	-	1	10,08
EGR 250	250	A	250	250	316	4	24	176	-	-	91	-	-	1	13,26
EGR 280	280	A	250	250	316	4	24	176	-	-	91	-	-	1	13,26
EGR 315	315	A	300	300	367	4	24	203	-	-	105	-	-	1	17,75
EGR 355	355	A	350	350	425	4	24	233	-	-	91	-	-	1	Consultar
EGR 400	400	A	400	400	477	4	24	261	-	-	102	-	-	1	Consultar
EGR 450	450	A	450	450	542	4	29	289	-	-	264	-	-	1	Consultar
EGR 500	500	B	500	500	576	5	32	305	325	26	-	282	463	1	Consultar
EGR 630	630	B	600	600	675	5	35	360	375	29	-	320	536	1	Consultar



Portabridas

Portabridas largo SDR11 PN16

Portabridas largo SDR17 PN10

Portabridas corto SDR11 PN16

Portabridas corto SDR17 PN10

Con Declaración Ambiental de Producto (DAP)



Portabridas y bridas

Portabridas largo PE100 RC SDR11 PFA/PN16

Descripción

-Accesorio inyectado a soldar por electrofusión o a tope.

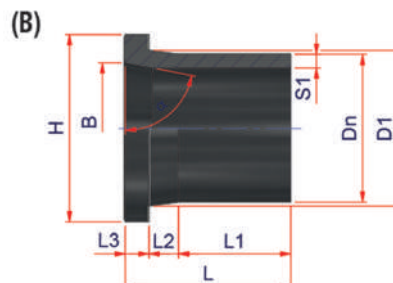
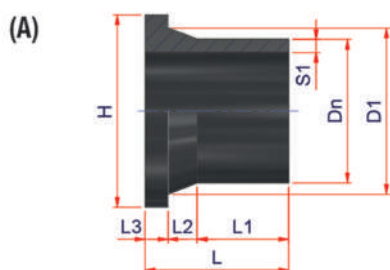

Referencia	Tipo	∅ (mm)	Dn (mm)	S (mm)	D1 (mm)	D (mm)	L1 (mm)	L2 (mm)	L (mm)	B (mm)	α (mm)	Uds. Caja	Precio (€/u.)
ECRT 25	A	25	25	3	33	58	42	9	78	-	-	90	2,55
ECRT 32	A	32	32	3	39	68	42	10	75	-	-	60	2,98
ECRT 40	A	40	40	3,7	50	78	63	11	95	-	-	30	3,52
ECRT 50	A	50	50	4,6	61	88	66	12	96	52	72,5°	24	4,29
ECRT 63	B	63	63	5,8	75	102	69,5	17	114	60	84°	30	5,40
ECRT 75	B	75	75	6,8	89	122	77	17	118	72	79°	20	6,99
ECRT 90	B	90	90	8,2	105	138	93,5	16	129	90	70°	30	9,12
ECRT 110	B	110	110	10	125	158	92	19	132	110	67,5°	60	11,64
ECRT 125	B	125	125	11,5	132	158,5	95	20	141	111	79°	60	14,18
ECRT 140	A	140	140	12,7	155	189	100	23	172	130	79°	30	20,67
ECRT 160	B	160	160	14,6	173	212	102,5	24,5	158	156	71°	36	26,12
ECRT 180	A	180	180	16,4	180	212,5	146	26	175	152	84°	24	32,18
ECRT 200	A	200	200	18,2	232	268	140	31	208	200	72°	12	47,50
ECRT 225	A	225	225	20,5	235	268	136	33,5	205	207	80,5°	12	50,45
ECRT 250	A	250	250	22,7	285	320	144	35	221,5	260	65°	18	82,53
ECRT 280	A	280	280	25,4	289,5	320	149	36	215	244	81°	16	130,63
ECRT 315	A	315	315	28,6	332	370	172	37	250	298	69°	24	144,34
ECRT 355	A	355	355	32,3	373	430	166	40	246	-	-	8	Consultar
ECRT 400	A	400	400	36,4	427	485	182	47	274	-	-	5	Consultar
ECRT 450	A	450	450	40,9	514	585	200	60	315	-	-	2	Consultar
ECRT 500	A	500	500	45,5	500	585	390	60	535	-	-	2	Consultar
ECRT 560	A	560	560	50,9	615	685	240	80	380	-	-	1	Consultar
ECRT 630	A	630	630	57,3	643	680	260	50	350	-	-	3	Consultar

Portabridas y bridas

Portabridas corto PE100 RC SDR11 PFA/PN16

Descripción

- Accesorio a soldar a tope.
- Entrega: 15 días desde el pedido.

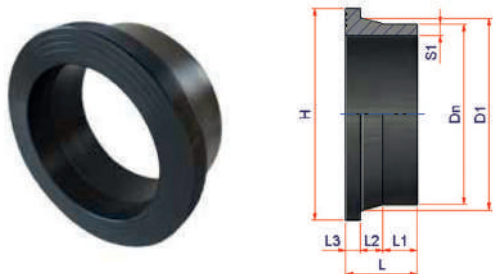

Referencia	Ø (mm)	Dn (mm)	S1 (mm)	L1 (mm)	D1 (mm)	L2 (mm)	L3 (mm)	L (mm)	H (mm)	Uds. Caja	Precio (€/u.)
ECRTC 110	110	110	10,0	25	125	25	18	68	158	120	11,20
ECRTC 125	125	125	11,4	35	132	20	25	80	158	40	13,52
ECRTC 140	140	140	12,7	27	155	28	25	80	188	1	21,05
ECRTC 160	160	160	14,6	27	175	28	25	80	212	60	25,34
ECRTC 180	180	180	16,4	20	180	30	30	80	212	50	30,88
ECRTC 200	200	200	18,2	28	232	40	32	100	268	10	39,58
ECRTC 225	225	225	20,5	38	235	30	32	100	268	18	52,40
ECRTC 250	250	250	22,7	55	285	32	35	122	320	12	65,86
ECRTC 280	280	280	25,4	55	291	35	35	125	320	16	63,53
ECRTC 315	315	315	28,6	55	333,5	42	38	135	370	18	92,50
ECRTC 355	355	355	32,3	55	373	47	43	150	430	16	Consultar
ECRTC400	400	400	36,4	29	427	45	46	120	485	9	Consultar
ECRTC 450	450	450	40,9	33	514	60	60	153	585	6	Consultar
ECRTC 500	500	500	45,5	15	530	50	60	125	585	6	Consultar
ECRTC 560	560	560	50,9	15	615	60	60	135	685	4	Consultar
ECRTC 630	630	630	57,3	20	642	40	60	120	685	9	Consultar
ECRTC 710	710	710	64,5	20	738	45	70	135	800	1	Consultar
ECRTC 800	800	800	72,6	23	836	42	70	145	905	1	Consultar

Portabridas y bridas

Portabridas largo PE100 RC SDR17 PFA/PN10

Descripción

-Accesorio inyectado a soldar por electrofusión o a tope.

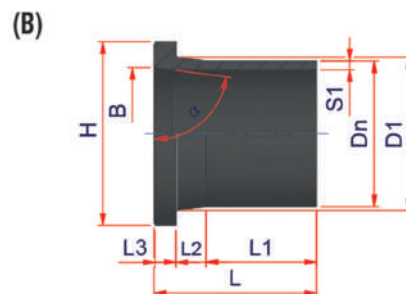
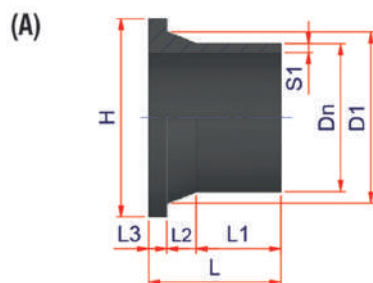

Referencia	Tipo	Ø (mm)	Dn (mm)	D1 (mm)	S1 (mm)	L1 (mm)	L2 (mm)	L3 (mm)	L (mm)	H (mm)	B (mm)	α (mm)	Uds. Caja	Precio (€/u.)
DCRT 63	B	63	63	75	3,8	69,5	26,5	16,7	113,7	102	63	80 °	30	5,40
DCRT 75	B	75	75	94	4,5	77	23	17	118	122	74	79,4 °	20	6,99
DCRT 90	B	90	90	105	5,4	82	31	17	130	138	87,5	74,5 °	30	9,12
DCRT 110	B	110	110	136	6,6	92	20	18	131	158	110	67,5 °	60	11,64
DCRT 125	B	125	125	132	7,4	95	26	18	140	158	114	82,4 °	60	14,18
DCRT 140	A	140	140	161	8,3	100	34	25	160	188	-	-	30	19,70
DCRT 160	B	160	160	175	9,5	103	29,5	24,5	158	211	150	82,3 °	36	21,85
DCRT 180	A	180	180	188	10,7	114	4	20	180	212	-	-	24	32,18
DCRT 200	A	200	200	232	11,9	114,5	40	24,5	179	268	-	-	12	38,90
DCRT 225	A	225	225	242	13,4	125	51	24	201,3	268	-	-	12	39,56
DCRT 250	A	250	250	285	14,8	142	40	25	207	320	-	-	18	75,78
DCRT 280	A	280	280	297,7	16,6	150	30	26	207	320	-	-	16	82,87
DCRT 315	A	315	315	335	18,8	152	40	25	217	370	-	-	24	113,12
DCRT 355	A	355	355	373	21,1	176	40	30	246	430	-	-	8	Consultar
DCRT 400	A	400	400	427	23,7	182	45	33	485	260	-	-	6	Consultar
DCRT 450	B	450	450	514	26,7	200	60	44,5	306	585	450	67,5 °	6	Consultar
DCRT 500	A	500	500	530	29,7	214	50	46	310	585	-	-	2	Consultar
DCRT 560	B	560	560	615	33,2	235	40	48,5	325	685	554	67,5 °	1	Consultar
DCRT 630	A	630	630	642	37,4	260	40	48,5	350	685	-	-	3	Consultar

Portabridas y bridas

Portabridas corto PE100 RC SDR17 PFA/PN10

Descripción

- Accesorio a soldar a tope.
- Entrega: 15 días desde el pedido.

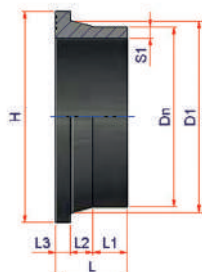

Referencia	∅ (mm)	Dn (mm)	S1 (mm)	L1 (mm)	D1 (mm)	L2 (mm)	L3 (mm)	L (mm)	H (mm)	Uds. Caja	Precio (€/u.)
DCRTC 110	110	110	6,6	25	125	25	18	68	158	45	13,05
DCRTC 125	125	125	7,4	36	132	25	19	80	158	15	16,91
DCRTC 140	140	140	8,3	34	155	28	18	80	188	1	28,78
DCRTC 160	160	160	9,5	34	175	28	18	80	212	22	24,43
DCRTC 180	180	180	10,7	30	180	30	20	80	212	1	38,62
DCRTC 200	200	200	20,5	36	232	40	24,5	85	268	10	40,77
DCRTC 225	225	225	13,4	46	235	30	24	100	268	7	53,66
DCRTC 250	250	250	14,8	35	285	40	25	100	320	15	65,56
DCRTC 280	280	280	16,6	45	291	30	25	100	320	13	83,04
DCRTC 315	315	315	18,8	35	335	40	25	100	370	8	91,27
DCRTC 355	355	355	21,1	45	373	40	30	115	430	6	Consultar
DCRTC 400	400	400	23,7	40	427	45	33	118	485	12	Consultar
DCRTC 450	450	450	26,7	24	514	60	46	130	585	6	Consultar
DCRTC 500	500	500	29,7	57	530	50	46	153	585	6	Consultar
DCRTC 560	560	560	33,2	15	615	60	50	125	685	4	Consultar
DCRTC 630	630	630	37,4	35	642	40	50	125	685	10	Consultar
DCRTC 710	710	710	42,1	20	738	50	50	120	800	1	Consultar
DCRTC 800	800	800	47,4	20	836	50	52	122	900	1	Consultar
DCRTC 900	900	900	53,3	20	944	50	55	125	1005	1	Consultar
DCRTC 1000	1000	1000	59,3	20	1047	50	60	130	1110	1	Consultar



Collares electrosoldables PE100 RC SDR11 PN16

Con Declaración Ambiental de Producto (DAP)



Collares electrosoldables

Collar electrosoldable de toma en carga con collarín inferior en material plástico PE100 RC SDR11 PFA/PN16

Descripción

- SDR mín: soldable con SDR 17,6 - 17 - 13,6 - 11.
- PF (mín SDR) = Profundidad máxima de perforación.
- (*) Con tubos SDR 17-17,6: a soldar solo sin presión.
- ⊙ Llave hexagonal de perforación (mm).

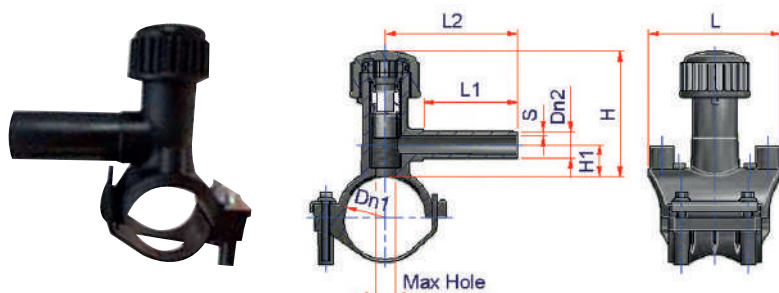

Referencia	Ø (mm)	PF SDR mín.*	Dn1 (mm)	Dn2 (mm)	S (mm)	L1 (mm)	L2 (mm)	L (mm)	H1 (mm)	H (mm)	Agujero máx. (mm)	⊙	Uds. Caja	Precio (€/u.)
EPRES04020	40-20	11	40	20	3	70	100	100	24	95	17	12	50	23,63
EPRES05020	50-20	11	50	20	3	70	100	100	24	95	17	12	40	25,78
EPRES06320	63-20	11	63	20	3	70	100	100	24	95	17	12	40	27,98
EPRES07520	75-20	11	75	20	3	70	100	100	24	95	17	12	30	33,33
EPRES09020	90-20	11	90	20	3	50	100	100	20	100	17	12	30	33,33
EPRES11020	110-20	11	110	20	3	50	100	100	20	100	17	12	25	36,69
EPRES12520	125-20	11	125	20	3	50	100	100	20	100	17	12	20	41,70
EPRES16020	160-20	11	160	20	3	70	100	100	23	110	17	12	20	52,90
EPRES18020	180-20	11	180	20	3	70	100	100	23	110	17	12	20	61,61
EPRES04025	40-25	11	40	25	3	70	100	100	24	95	17	12	40	29,91
EPRES05025	50-25	11	50	25	3	70	100	100	24	95	17	12	40	31,40
EPRES06325	63-25	11	63	25	3	70	100	100	24	95	17	12	40	33,49
EPRES07525	75-25	11	75	25	3	70	100	100	24	95	17	12	30	40,70
EPRES09025	90-25	11	90	25	3	50	100	100	20	100	17	12	30	37,22
EPRES11025	110-25	11	110	25	3	50	100	100	20	100	17	12	25	44,10
EPRES12525	125-25	11	125	25	3	70	100	100	20	100	17	12	25	50,89
EPRES16025	160-25	11	160	25	3	70	100	100	23	110	17	12	20	70,86
EPRES18025	180-25	11	180	25	3	70	100	100	23	110	17	12	20	75,71
EPRES04032	40-32	11	40	32	3	70	100	100	24	95	17	12	50	30,90
EPRES05032	50-32	11	50	32	3	70	100	100	24	95	17	12	40	31,40
EPRES06332	63-32	11	63	32	3	70	100	100	24	95	17	12	35	33,49
EPRES07532	75-32	11	75	32	3	70	100	100	24	95	17	12	30	40,70
EPRES09032	90-32	11	90	32	3	50	100	100	20	100	17	12	25	40,94
EPRES11032	110-32	11	110	32	3	50	100	100	20	100	17	12	20	44,10
EPRES12532	125-32	11	125	32	3	50	100	100	20	100	17	12	20	51,04
EPRES16032	160-32	11	160	32	3	70	100	100	23	110	17	12	20	69,96
EPRES18032	180-32	11	180	32	3	70	100	100	23	110	17	12	20	70,86
EPRES06340	63-40	11	63	40	3,7	70	100	120	32	128	23	10	25	40,51
EPRES06350	63-50	11	63	50	4,6	62	100	130	32	145	31	12	20	53,16
EPRES09050	90-50	11	90	50	4,6	90	136	150	62	210	40,5	14	10	63,12
EPRES11050	110-50	11	110	50	4,6	90	136	150	62	210	40,5	14	10	66,21
EPRES06363	63-63	11	63	63	5,8	62	100	130	30	145	31	12	20	53,16
EPRES09063	90-63	11	90	63	5,8	90	134	150	59	210	40,5	14	10	63,12
EPRES11063	110-63	11	110	63	5,8	90	134	150	59	210	29,5	12	10	66,21

Collares electrosoldables

Collar electrosoldable de toma en carga con cinta PE100 RC SDR11 PFA/PN16

Descripción

-(*) SDR mín. soldables con tubería SDR 17,6 - 17 - 13,6 - 11

-PF: Máxima profundidad de perforación

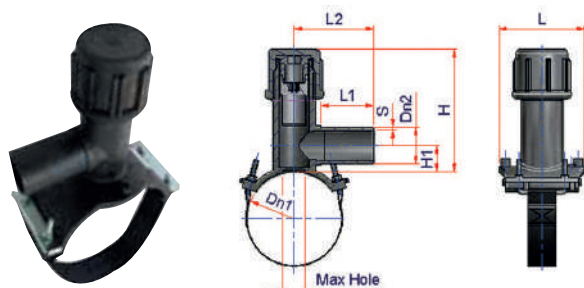

Referencia	∅ (mm)	PF SDR mín.*	Dn1 (mm)	Dn2 (mm)	S (mm)	L1 (mm)	L2 (mm)	L (mm)	H1 (mm)	H (mm)	Agujero máx. (mm)		Uds. Caja	Precio (€/u.)
EPRES14020	140-20	11	140	20	3,0	70	105	116	30	125	24	10	20	52,90
EPRES20020	200-20	11	200	20	3,0	70	105	116	30	125	24	10	30	72,51
EPRES22520	225-20	11	225	20	3,0	70	105	150	40	160	24	10	10	76,67
EPRES25020	250-20	11	250	20	3,0	70	105	150	40	160	24	10	10	107,50
EPRES28020	280-20	11	280	20	3,0	70	105	150	40	160	24	10	10	110,34
EPRES31520	315-20	11	315	20	3,0	70	105	150	40	160	24	10	10	113,36
EPRES14025	140-25	11	140	25	3,0	70	105	116	30	125	24	10	30	68,06
EPRES20025	200-25	11	200	25	3,0	70	105	116	30	125	24	10	25	83,45
EPRES22525	225-25	11	225	25	3,0	70	105	150	40	160	24	10	10	88,63
EPRES25025	250-25	11	250	25	3,0	70	105	150	40	160	24	10	10	127,24
EPRES28025	280-25	11	280	25	3,0	70	105	150	40	160	24	10	10	110,34
EPRES31525	315-25	11	315	25	3,0	70	105	150	40	160	24	10	10	113,36
EPRES14032	140-32	11	140	32	3,0	70	105	116	30	125	24	10	30	68,06
EPRES20032	200-32	11	200	32	3,0	70	105	116	30	125	24	10	30	76,86
EPRES22532	225-32	11	225	32	3,0	70	105	150	40	160	24	10	10	76,67
EPRES25032	250-32	11	250	32	3,0	70	105	150	40	160	24	10	10	107,50
EPRES28032	280-32	11	280	32	3,0	70	105	150	40	160	24	10	10	110,34
EPRES31532	315-32	11	315	32	3,0	70	105	150	40	160	24	10	10	113,36
EPRES07540	75-40	11	75	40	3,7	70	105	116	30	125	24	10	25	41,82
EPRES09040	90-40	11	90	40	3,7	70	105	116	30	125	24	10	25	41,82
EPRES11040	110-40	11	110	40	3,7	70	105	116	30	125	24	10	25	45,43
EPRES12540	125-40	11	125	40	3,7	70	105	116	30	125	24	10	30	64,47
EPRES14040	140-40	11	140	40	3,7	70	105	116	30	125	24	10	30	64,30
EPRES16040	160-40	11	160	40	3,7	70	105	116	30	125	24	10	30	70,28
EPRES18040	180-40	11	180	40	3,7	70	105	116	30	125	24	10	30	64,47
EPRES20040	200-40	11	200	40	3,7	70	105	116	30	125	24	10	30	87,28
EPRES22540	225-40	11	225	40	3,7	70	105	150	42	165	24	10	10	92,09
EPRES25040	250-40	11	250	40	3,7	70	105	150	42	165	24	10	10	131,70
EPRES28040	280-40	11	280	40	3,7	70	105	150	42	165	24	10	10	110,34
EPRES31540	315-40	11	315	40	3,7	70	105	150	42	165	24	10	10	133,53

Collares electrosoldables

Collar electrosoldable de toma en carga con cinta PE100 RC SDR11 PFA/PN16

Descripción

-(*) SDR mín. soldables con tubería SDR 17,6 - 17 - 13,6 - 11

-PF: Máxima profundidad de perforación

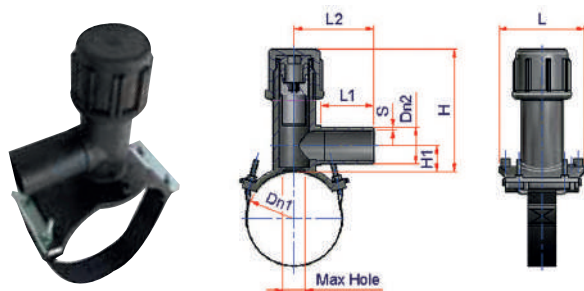

Referencia	∅ (mm)	PF SDR mín.*	Dn1 (mm)	Dn2 (mm)	S (mm)	L1 (mm)	L2 (mm)	L (mm)	H1 (mm)	H (mm)	Agujero máx. (mm)		Uds. Caja	Precio (€/u.)
EPRES07550	75-50	11	75	50	4,6	90	136	150	62	210	40,5	14	10	116,60
EPRES12550	125-50	11	125	50	4,6	90	136	150	62	210	40,5	14	10	67,93
EPRES14050	140-50	11	140	50	4,6	90	136	150	62	210	40,5	14	10	69,68
EPRES16050	160-50	11	160	50	4,6	90	136	150	62	210	40,5	14	10	71,42
EPRES18050	180-50	11	180	50	4,6	90	136	150	62	210	40,5	14	6	76,34
EPRES20050	200-50	11	200	50	4,6	90	136	150	62	210	40,5	14	6	96,66
EPRES22550	225-50	11	225	50	4,6	90	136	150	62	210	40,5	14	6	105,43
EPRES25050	250-50	11	250	50	4,6	90	136	150	62	210	40,5	14	6	131,33
EPRES28050	280-50	11	280	50	4,6	90	136	150	62	210	40,5	14	6	136,18
EPRES31550	315-50	11	315	50	4,6	90	136	150	62	210	40,5	14	6	127,25
EPRES07563	75-63	11	75	63	5,8	90	134	150	62	210	40,5	14	10	116,60
EPRES12563	125-63	11	125	63	5,8	90	134	150	62	210	40,5	14	10	67,93
EPRES14063	140-63	11	140	63	5,8	90	134	150	62	210	40,5	14	10	69,68
EPRES16063	160-63	11	160	63	5,8	90	134	150	62	210	40,5	14	10	70,18
EPRES18063	180-63	11	180	63	5,8	90	134	150	62	210	40,5	14	6	76,34
EPRES20063	200-63	11	200	63	5,8	90	134	150	62	210	40,5	14	6	87,15
EPRES22563	225-63	11	225	63	5,8	90	134	150	62	210	40,5	14	6	105,43
EPRES25063	250-63	11	250	63	5,8	90	134	150	62	210	40,5	14	6	131,33
EPRES28063	280-63	11	280	63	5,8	90	134	150	62	210	40,5	14	6	117,22
EPRES31563	315-63	11	315	63	5,8	90	134	150	62	210	40,5	14	6	127,25

Collares electrosoldables

Collar de derivación electrosoldable PE100 RC SDR11 PFA/PN16

Descripción

- Con collarín interior en material plástico
- (*) SDR mín: soldable con SDR 17,6 - 17 - 13,6 - 11 - 9 - 7,4
- (*) Con tubos SDR 17-17,6: a soldar solo sin presión.

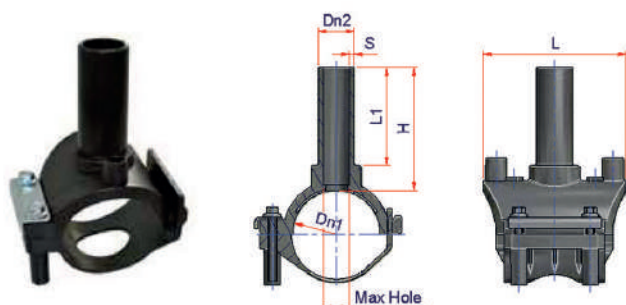

Referencia	∅ (mm)	SDR mín.*	Dn1 (mm)	Dn2 (mm)	S (mm)	L1 (mm)	L (mm)	H (mm)	Agujero máx. (mm)	Uds. Caja	Precio (€/u.)
ECOL 4020 •	40-20	17,6	40	20	3	70	100	82	13	100	19,32
ECOL 5020 •	50-20	17,6	50	20	3	70	100	82	13	60	22,92
ECOL 6320 •	63-20	17,6	63	20	3	70	100	82	13	70	24,92
ECOL 7520	75-20	17,6	75	20	3	70	100	82	13	60	26,77
ECOL09020	90-20	17,6	90	20	3	70	100	82	13	30	28,60
ECOL11020	110-20	17,6	110	20	3	70	100	98	13	30	30,29
ECOL 4025 •	40-25	17,6	40	25	3	70	100	82	16	70	19,32
ECOL 5025 •	50-25	17,6	50	25	3	70	100	82	16	50	22,92
ECOL 6325 •	63-25	17,6	63	25	3	70	100	82	16	70	24,92
ECOL 7525	75-25	17,6	75	25	3	70	100	82	16	40	26,77
ECOL 09025	90-25	17,6	90	25	3	70	100	98	18	30	28,60
ECOL 4032 •	40-32	17,6	40	32	3	70	100	82	22,5	70	19,32
ECOL 5032 •	50-32	17,6	50	32	3	70	100	82	22,5	70	22,92
ECOL 6332	63-32	17,6	63	32	3	70	100	82	22,5	70	24,92
ECOL 7532	75-32	17,6	75	32	3	70	100	82	22,5	60	26,77
ECOL09032	90-32	17,6	90	32	3	75	106	98	25	30	28,60
ECOL11032	110-32	17,6	110	32	3	72,5	100	97	22,5	30	30,29
ECOL 4040	40-40	17,6	40	40	3,7	70	100	82	30	60	16,44
ECOL 5040	50-40	17,6	50	40	3,7	70	100	82	30	50	22,92
ECOL 6340	63-40	17,6	63	40	3,7	70	100	82	30	40	24,92
ECOL 7540	75-40	17,6	75	40	3,7	70	100	82	30	40	26,77
ECOL 6350	63-50	17,6	63	50	4,6	75	132	110	37	30	54,96
ECOL09063	90-63	17,6	90	63	5,8	82	140	100	44	20	28,60
ECOL11063	110-63	17,6	110	63	5,8	82	140	100	44	20	30,29
ECOL12563	125-63	17,6	125	63	5,8	82	140	100	44	20	32,69

Collares electrosoldables

Collar de derivación electrosoldable con cinta PE100 RC SDR11 PFA/PN16

Descripción

-(*) SDR mín: soldable con SDR 17,6 - 17 - 13,6 - 11 - 9 - 7,4.

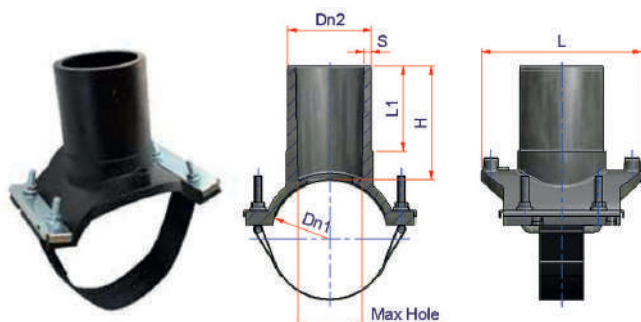

Referencia	Ø (mm)	SDR mín.*	Dn1 (mm)	Dn2 (mm)	S (mm)	L1 (mm)	L (mm)	H (mm)	Agujero máx. (mm)	Uds. Caja	Precio (€/u.)
ECOL12520	125-20	17,6	125	20	3	65	140	100	13	30	32,69
ECOL14020	140-20	17,6	140	20	3	65	140	100	13	30	43,14
ECOL16020	160-20	17,6	160	20	3	65	140	100	13	30	49,18
ECOL18020	180-20	17,6	180	20	3	65	140	100	13	30	49,17
ECOL20020	200-20	17,6	200	20	3	65	140	100	13	30	64,92
ECOL22520	225-20	17,6	225	20	3	65	140	100	13	30	69,39
ECOL25020	250-20	17,6	250	20	3	65	140	100	13	30	105,17
ECOL28020	280-20	17,6	280	20	3	65	140	100	13	30	107,32
ECOL31520	315-20	17,6	315	20	3	65	140	100	13	30	108,55
ECOL11025	110-25	17,6	110	25	3	65	140	100	16	30	30,29
ECOL12525	125-25	17,6	125	25	3	65	140	100	16	30	32,69
ECOL14025	140-25	17,6	140	25	3	65	140	100	16	30	43,14
ECOL16025	160-25	17,6	160	25	3	65	140	100	16	30	49,18
ECOL18025	180-25	17,6	180	25	3	65	140	100	16	30	52,62
ECOL20025	200-25	17,6	200	25	3	65	140	100	16	30	64,92
ECOL22525	225-25	17,6	225	25	3	65	140	100	16	30	69,39
ECOL25025	250-25	17,6	250	25	3	65	140	100	16	30	105,17
ECOL28025	280-25	17,6	280	25	3	65	140	100	16	30	107,32
ECOL31525	315-25	17,6	315	25	3	65	140	100	16	30	108,55
ECOL12532	125-32	17,6	125	32	3	65	140	100	22,5	30	32,69
ECOL14032	140-32	17,6	140	32	3	65	140	100	22,5	30	43,14
ECOL16032	160-32	17,6	160	32	3	65	140	100	22,5	30	49,18
ECOL18032	180-32	17,6	180	32	3	65	140	100	22,5	30	52,62
ECOL20032	200-32	17,6	200	32	3	65	140	100	22,5	30	64,92
ECOL22532	225-32	17,6	225	32	3	65	140	100	22,5	30	69,39
ECOL25032	250-32	17,6	250	32	3	65	140	100	22,5	30	105,17
ECOL28032	280-32	17,6	280	32	3	65	140	100	22,5	30	107,32
ECOL31532	315-32	17,6	315	32	3	65	140	100	22,5	30	108,55

Collares electrosoldables

Collar de derivación electrosoldable con cinta PE100 RC SDR11 PFA/PN16

Descripción

-(*) SDR mín: soldable con SDR 17,6 - 17 - 13,6 - 11 - 9 - 7,4.

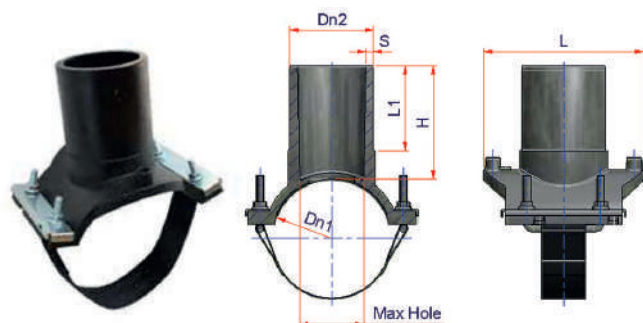

Referencia	Ø (mm)	SDR mín.*	Dn1 (mm)	Dn2 (mm)	S (mm)	L1 (mm)	L (mm)	H (mm)	Agujero máx. (mm)	Uds. Caja	Precio (€/u.)
ECOL11040	110-40	17,6	110	40	3,7	65	140	100	30	30	30,29
ECOL12540	125-40	17,6	125	40	3,7	65	140	100	30	30	32,69
ECOL14040	140-40	17,6	140	40	3,7	65	140	100	30	30	43,14
ECOL16040	160-40	17,6	160	40	3,7	65	140	100	30	30	49,19
ECOL18040	180-40	17,6	180	40	3,7	65	140	100	30	30	53,77
ECOL20040	200-40	17,6	200	40	3,7	65	140	100	30	30	64,92
ECOL22540	225-40	17,6	225	40	3,7	65	140	100	30	30	69,39
ECOL25040	250-40	17,6	250	40	3,7	65	140	100	30	30	105,17
ECOL28040	280-40	17,6	280	40	3,7	65	140	100	30	30	107,32
ECOL31540	315-40	17,6	315	40	3,7	65	140	100	30	30	108,55
ECOL 7550	75-50	17,6	75	50	4,6	65	140	100	38	30	26,77
ECOL09050	90-50	17,6	90	50	4,6	65	140	100	38	30	28,60
ECOL11050	110-50	17,6	110	50	4,6	65	140	100	38	30	30,29
ECOL12550	125-50	17,6	125	50	4,6	65	140	100	38	30	32,69
ECOL14050	140-50	17,6	140	50	4,6	65	140	100	38	30	43,14
ECOL16050	160-50	17,6	160	50	4,6	65	140	100	38	30	49,18
ECOL18050	180-50	17,6	180	50	4,6	65	140	100	38	30	55,34
ECOL20050	200-50	17,6	200	50	4,6	65	140	100	38	30	64,92
ECOL22550	225-50	17,6	225	50	4,6	65	140	100	38	30	69,39
ECOL25050	250-50	17,6	250	50	4,6	65	140	100	38	30	105,17
ECOL28050	280-50	17,6	280	50	4,6	65	140	100	38	30	107,32
ECOL31550	315-50	17,6	315	50	4,6	65	140	100	38	25	108,55
ECOL 7563	75-63	17,6	75	63	5,8	65	140	100	44	25	26,77
ECOL14063	140-63	17,6	140	63	5,8	65	140	100	44	30	43,14
ECOL16063	160-63	17,6	160	63	5,8	65	140	100	44	30	49,18
ECOL18063	180-63	17,6	180	63	5,8	65	140	100	44	30	52,62
ECOL20063	200-63	17,6	200	63	5,8	65	140	100	44	30	64,92
ECOL22563	225-63	17,6	225	63	5,8	65	140	100	44	30	69,39
ECOL25063	250-63	17,6	250	63	5,8	65	140	100	44	30	105,17
ECOL28063	280-63	17,6	280	63	5,8	65	140	100	44	8	107,32
ECOL31563	315-63	17,6	315	63	5,8	65	140	100	44	8	108,55

Collares electrosoldables

Collar de derivación electrosoldable "gran caudal" con cinta PE100 RC SDR11 PFA/PN16

Descripción

-(*) SDR mín: soldable con SDR 17,6 - 17 - 13,6 - 11 - 9 - 7,4.

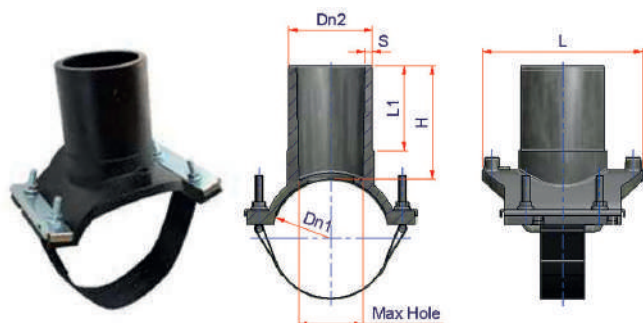

Referencia	Ø (mm)	SDR mín.*	Dn1 (mm)	Dn2 (mm)	S (mm)	L1 (mm)	L (mm)	H (mm)	Agujero máx. (mm)	Uds. Caja	Precio (€/u.)
ECOL11075	110-75	17,6	110	75	6,8	90	170	120	59	15	84,78
ECOL12575	125-75	17,6	125	75	6,8	90	170	120	59	15	95,21
ECOL14075	140-75	17,6	140	75	6,8	90	170	120	59	15	102,50
ECOL16075	160-75	17,6	160	75	6,8	90	170	120	59	15	114,25
ECOL18075	180-75	17,6	180	75	6,8	90	170	120	59	15	121,18
ECOL20075	200-75	17,6	200	75	6,8	90	170	120	59	15	132,09
ECOL11090	110-90	17,6	110	90	8,2	90	170	120	70	15	96,35
ECOL12590	125-90	17,6	125	90	8,2	90	170	120	70	15	103,86
ECOL14090	140-90	17,6	140	90	8,2	90	170	120	70	15	113,48
ECOL16090	160-90	17,6	160	90	8,2	90	170	120	70	15	121,66
ECOL18090	180-90	17,6	180	90	8,2	90	170	120	70	15	132,71
ECOL20090	200-90	17,6	200	90	8,2	90	170	120	70	15	139,29
ECOL22590	225-90	17,6	225	90	8,2	98	200	130	70	6	150,02
ECOL25090	250-90	17,6	250	90	8,2	98	200	130	70	6	157,47
ECOL28090	280-90	17,6	280	90	8,2	98	200	130	70	6	169,26
ECOL31590	315-90	17,6	315	90	8,2	98	200	130	70	6	175,88
ECOL125110	125-110	17,6	125	110	10	90	200	140	87	10	111,68
ECOL160110	160-110	17,6	160	110	10	98	200	130	87	7	132,24
ECOL180110	180-110	17,6	180	110	10	98	200	130	87	6	140,80
ECOL200110	200-110	17,6	200	110	10	98	200	130	87	8	150,10
ECOL225110	225-110	17,6	225	110	10	98	200	130	87	5	158,06
ECOL250110	250-110	17,6	250	110	10	98	200	130	87	5	168,93
ECOL280110	280-110	17,6	280	110	10	98	200	130	87	5	181,57
ECOL315110	315-110	17,6	315	110	10	98	200	130	87	6	188,44
ECOL160125	160-125	17,6	160	125	11,4	98	200	130	100	6	139,65
ECOL180125	180-125	17,6	180	125	11,4	98	200	130	100	6	150,02
ECOL200125	200-125	17,6	200	125	11,4	98	200	130	100	7	158,50
ECOL225125	225-125	17,6	225	125	11,4	98	200	130	100	5	167,46
ECOL250125	250-125	17,6	250	125	11,4	98	200	130	100	5	178,95
ECOL280125	280-125	17,6	280	125	11,4	98	200	130	100	5	192,34
ECOL315125	315-125	17,6	315	125	11,4	98	200	130	100	6	196,30

Collares electrosoldables

Collar de derivación gran volumen "top load" PE100 RC SDR11 PFA/PN16

Descripción

- Para instalar esta pieza consultar herramientas para su instalación
- (*) SDR mín: soldables en SDR 17,6 - 17 - 13,6 - 11 - 9 - 7,4

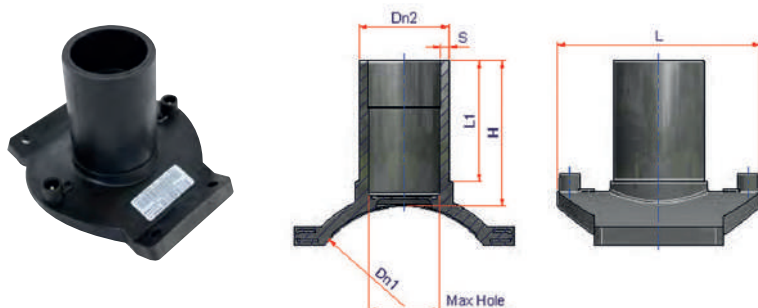

Referencia	Ø (mm)	SDR mín.*	Dn1 (mm)	Dn2 (mm)	S (mm)	L1 (mm)	L (mm)	H (mm)	Agujero máx. (mm)	Uds. Caja	Precio (€/u.)
ECOLTL356363	355/630-63	17,6	355/630	63	5,8	85	140	102	47	30	239,17

Collar de derivación PE/Latón rosca hembra PE100 RC SDR11 PFA/PN16

Descripción

- Tipo A: compuesto de un racor de transición PE/Latón 63x2" soldado a un collarín con correa.
- Tipo B: collar de transición con correa (obtenido por moldeo).
- (*) SDR mín. soldables con tubería SDR 17,6 - 17 - 13,6 - 11 - 9 - 7,4.

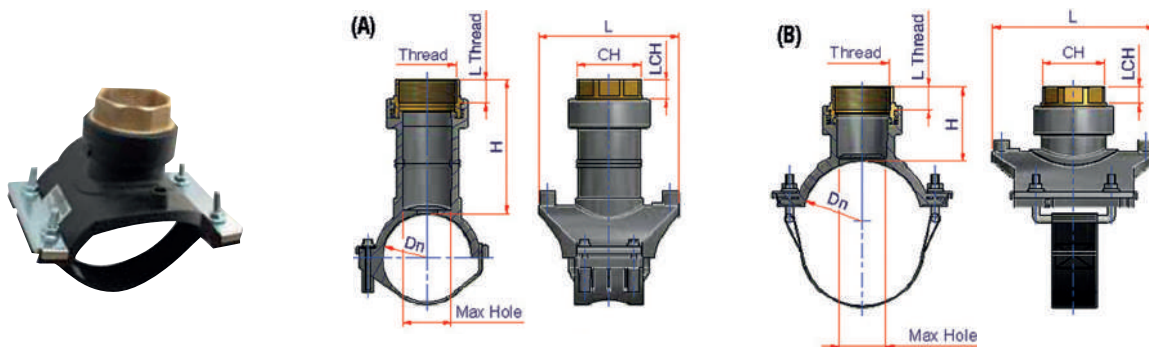

Referencia	Tipo	Ø (mm)	SDR mín.*	Dn (mm)	Rosca	L Rosca (mm)	L (mm)	H (mm)	CH (mm)	LCH (mm)	Agujero máx. (mm)	Uds. Caja	Precio (€/u.)
ECOLF075	A	75 x 2"	17,6	75	2" ISO 228	23,7	140	145	65	20	44	20	76,37
ECOLF090	A	90 x 2"	17,6	90	2" ISO 228	23,7	140	145	65	20	44	10	161,32
ECOLF110	B	110 x 2"	17,6	110	2" ISO 228	23,7	170	78	65	20	51	10	162,96
ECOLF125	B	125 x 2"	17,6	125	2" ISO 228	23,7	170	78	65	20	51	10	166,26
ECOLF140	B	140 x 2"	17,6	140	2" ISO 228	23,7	170	78	65	20	51	10	169,55
ECOLF160	B	160 x 2"	17,6	160	2" ISO 228	23,7	170	78	65	20	51	10	176,13
ECOLF180	B	180 x 2"	17,6	180	2" ISO 228	23,7	170	78	65	20	51	10	182,73
ECOLF200	B	200 x 2"	17,6	200	2" ISO 228	23,7	170	78	65	20	51	10	198,77
ECOLF225	A	225 x 2"	17,6	225	2" ISO 228	23,7	140	145	65	20	44	3	203,15
ECOLF250	A	250 x 2"	17,6	250	2" ISO 228	23,7	140	145	65	20	44	10	246,10
ECOLF280	A	280 x 2"	17,6	280	2" ISO 228	23,7	140	145	65	20	44	8	250,73
ECOLF315	A	315 x 2"	17,6	315	2" ISO 228	23,7	140	145	65	20	44	7	262,56



Accesorios inyectados polivalentes PE100 RC SDR11 PN16

Con Declaración Ambiental de Producto (DAP)



Accesorios inyectados polivalentes

Codo 90° largo

PE100 RC SDR11 PFA/PN16

Descripción

- Accesorio inyectado a soldar por electrofusión o a tope.
- (*) Accesorio de codo corto prolongado con tubo PE.

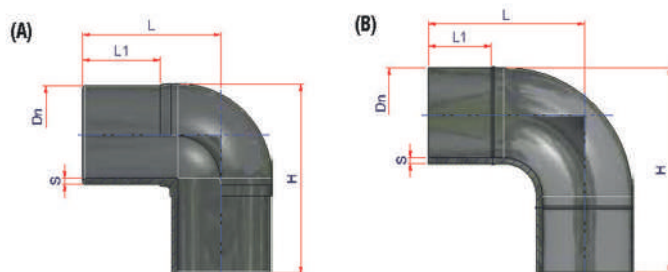

Referencia	Tipo	Ø (mm)	Dn (mm)	S (mm)	L1 (mm)	L (mm)	H (mm)	Uds. Caja	Precio (€/u.)
EG 25	A	25	25	3,0	45	70	84	30	3,50
EG 32	A	32	32	3,0	50	75	93	50	4,03
EG 40	A	40	40	3,7	55	85	107	30	4,25
EG 50	A	50	50	4,6	55	90	120	20	5,10
EG 63	A	63	63	5,8	70	120	154	50	7,31
EG 75	A	75	75	6,8	75	130	171	30	10,10
EG 90	A	90	90	8,2	89	146	197	24	13,94
EG 110	A	110	110	10,0	87	155	212,5	12	26,73
EG 125	A	125	125	11,4	95	184	250,5	24	37,30
EG 140	A	140	140	12,7	97	195	268	20	49,90
EG 160	A	160	160	14,6	101	210	293,5	12	60,77
EG 180	A	180	180	16,4	109	230	323,5	18	86,64
EG 200	A	200	200	18,2	116	250	354	16	107,32
EG 225	A	225	225	20,5	125	275	392	12	128,15
EG 250	A	250	250	22,7	135	305	435	10	213,01
EG 280	A	280	280	25,4	140	340	485	7	328,78
EG 315	A	315	315	28,6	165	360	518	4	404,24
EG 355*	B	355	355	32,2	210	550	727,5	2	Consultar
EG 400*	B	400	400	36,3	300	645	845	2	Consultar
EG 450*	B	450	450	40,9	300	745	970	1	Consultar
EG 500*	B	500	500	45,4	300	745	995	1	Consultar

Accesorios inyectados polivalentes

Codo 45° largo PE100 RC SDR11 PFA/PN16

Descripción

- Codos inyectados.
- (*) Codo corto prolongado con tubo PE.

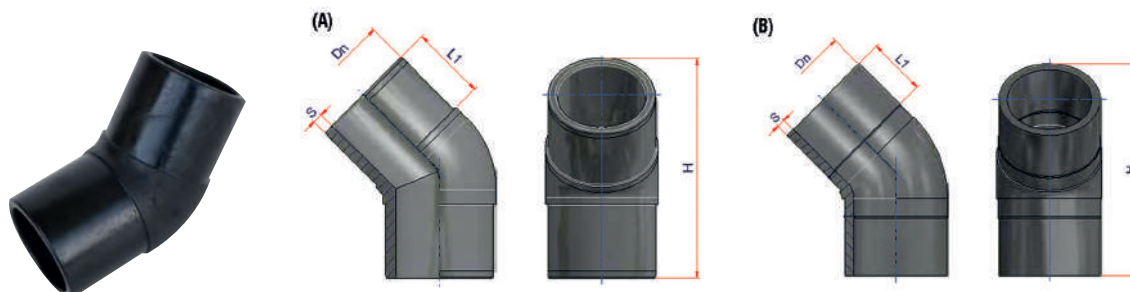

Referencia	Tipo	∅ (mm)	Dn (mm)	S (mm)	L1 (mm)	H (mm)	Uds. Caja	Precio (€/u.)
EC 32	A	32	32	3,0	50	121	30	4,25
EC 40	A	40	40	3,7	58	135	35	4,82
EC 50	A	50	50	4,6	59	145	20	5,93
EC 63	A	63	63	5,8	69	175	60	10,02
EC 75	A	75	75	6,8	75	205	40	12,45
EC 90	A	90	90	8,2	90	235	25	14,81
EC 110	A	110	110	10,0	87	242	12	28,40
EC 125	A	125	125	11,4	95	264,5	10	35,07
EC 140	A	140	140	12,7	97	287	8	45,90
EC 160	A	160	160	14,6	103	311	6	53,04
EC 180	A	180	180	16,4	110	369	10	58,06
EC 200	A	200	200	18,2	117	402	16	79,33
EC 225	A	225	225	20,5	125	436	15	94,57
EC 250	A	250	250	22,7	135	462	12	183,16
EC 280	A	280	280	25,4	140	520	8	336,24
EC 315	A	315	315	28,6	160	570	9	390,69
EC 355*	B	355	355	32,3	210	700	3	Consultar
EC 400*	B	400	400	36,4	300	860	2	Consultar
EC 450*	B	450	450	40,9	300	960	1	Consultar
EC 500*	B	500	500	45,4	300	980	1	Consultar

Accesorios inyectados polivalentes

Te 90° larga PE100 RC SDR11 PFA/PN16

Descripción

-Accesorio inyectado a soldar por electrofusión o a tope.

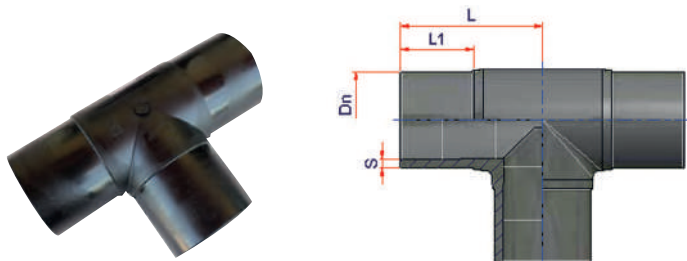

Referencia	Ø (mm)	Dn (mm)	S (mm)	D (mm)	L1 (mm)	L (mm)	H (mm)	Uds. Caja	Precio (€/u.)
ET 25	25	25	3	28	60	155	91,5	30	4,67
ET 32	32	32	3	34	60	163	98,5	20	5,08
ET 40	40	40	3,7	42	60	168	105	20	5,72
ET 50	50	50	4,6	53	57	180	116,5	16	6,69
ET 63	63	63	5,8	68	70	240	154	30	8,76
ET 75	75	75	6,8	82	75	260	171	25	14,54
ET 90	90	90	8,2	97,5	90	297	197	15	20,68
ET 110	110	110	10	122	87	320	221	9	30,27
ET 125	125	125	11,4	131	95	370	250,5	5	41,55
ET 140	140	140	12,7	146,5	97	390	268	15	66,77
ET 160	160	160	14,6	167	103	420	293,5	8	86,64
ET 180	180	180	16,4	187,5	110	460	324	16	113,69
ET 200	200	200	18,2	208,5	117	500	354	10	162,87
ET 225	225	225	20,5	234,5	125	550	392	9	193,55
ET 250	250	250	22,7	260,5	135	610	435	7	263,05
ET 280	280	280	25,4	288	155	650	469	4	447,04
ET 315	315	315	28,6	328,5	169	717	523	3	505,16
ET 355	355	355	32,3	370	166	826	598	1	Consultar
ET 400	400	400	36,3	415	197	940	677,5	1	Consultar

Accesorios inyectados polivalentes

Te 90° reducida larga PE100 RC SDR11 PFA/PN16

Descripción

- Accesorio inyectado a soldar por electrofusión o a tope.
- Según stock producción, el accesorio se puede suministrar inyectado o manipulado.

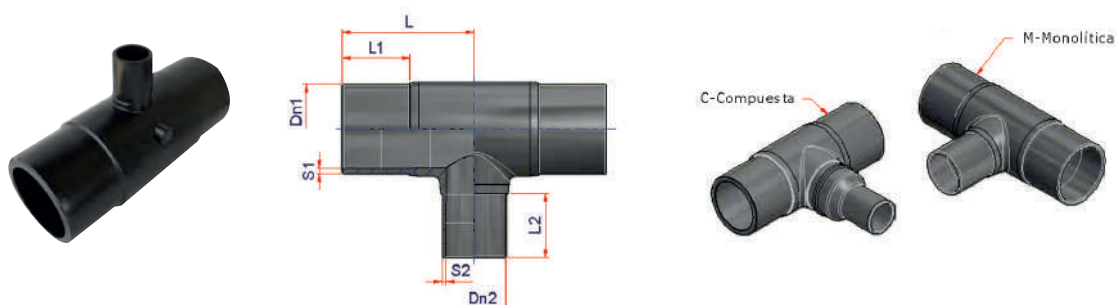

Referencia	Ø (mm)	Dn1 (mm)	S1 (mm)	L1 (mm)	Dn2 (mm)	S2 (mm)	L2 (mm)	L (mm)	Uds. Caja	Precio (€/u.)
ETRS6332	63-32	63	5,8	70	32	3,0	50	120	40	22,25
ETRS6350	63-50	63	5,8	70	50	4,6	58	120	25	22,25
ETRS7550	75-50	75	6,9	70	50	4,6	58	117	20	28,04
ETRS7563	75-63	75	6,9	70	63	5,8	58	117	20	28,04
ETRS9050	90-50	90	8,2	84	50	4,6	60	127	20	40,45
ETRS9063	90-63	90	8,2	84	63	5,8	70	127	15	40,45
ETRS9075	90-75	90	8,2	90	75	6,9	75	148,5	12	45,19
ETRS1140	110-40	110	10,0	87	40	3,7	65	155	12	50,19
ETRS1150	110-50	110	10,0	87	50	4,6	70	155	10	50,19
ETRS1163	110-63	110	10,0	87	63	5,8	87	155	10	35,13
ETRS1175	110-75	110	10,0	87	75	6,9	78	155	6	35,13
ETRS1190	110-90	110	10,0	87	90	8,2	90	155	10	35,13
ETRS1263	125-63	125	11,4	95	63	5,8	70	185	20	53,39
ETRS1275	125-75	125	11,4	95	75	6,9	75	185	20	53,39
ETRS1290	125-90	125	11,4	95	90	8,2	90	185	18	53,39
ETRS1211	125-110	125	11,4	95	110	10,0	87	185	18	53,39
ETRS1463	140-63	140	12,7	105	63	5,8	77	193	15	78,92
ETRS1475	140-75	140	12,7	105	75	6,8	78	193	16	81,33
ETRS1490	140-90	140	12,7	105	90	8,2	87	193	12	81,33
ETRS1411	140-110	140	12,7	105	110	10,0	95	193	13	81,33
ETRS1663	160-63	160	14,6	103	63	5,8	70	190	9	92,57
ETRS1675	160-75	160	14,6	103	75	6,8	75	190	30	92,58
ETRS1690	160-90	160	14,6	103	90	8,2	90	190	11	92,57
ETRS1611	160-110	160	14,6	103	110	10,0	87	190	10	92,57
ETRS1612	160-125	160	14,6	103	125	11,4	95	190	9	132,24
ETRS1875	180-75	180	16,4	116	75	6,8	93	230	6	144,54
ETRS1890	180-90	180	16,4	110	90	8,2	90	220	20	128,14
ETRS1811	180-110	180	16,4	110	110	10	87	220	18	128,14
ETRS1812	180-125	180	16,4	110	125	11,4	95	220	18	144,70
ETRS1814	180-140	180	16,4	116	140	12,7	104	230	5	144,70
ETRS1816	180-160	180	16,4	110	160	14,6	103	220	17	128,14
ETRS2063	200-63	200	18,2	117	63	5,8	70	230	6	162,38
ETRS2075	200-75	200	18,2	117	75	6,9	75	230	1	167,45
ETRS2090	200-90	200	18,2	117	90	8,2	90	230	6	162,38
ETRS2011	200-110	200	18,2	117	110	10,0	87	230	6	162,38
ETRS2012	200-125	200	18,2	117	125	11,4	95	230	6	162,38
ETRS2016	200-160	200	18,2	117	160	14,6	103	230	5	162,38

Accesorios inyectados polivalentes

Te 90° reducida larga PE100 RC SDR11 PFA/PN16

Descripción

- Accesorio inyectado a soldar por electrofusión o a tope.
- Según stock producción, el accesorio se puede suministrar inyectado o manipulado.

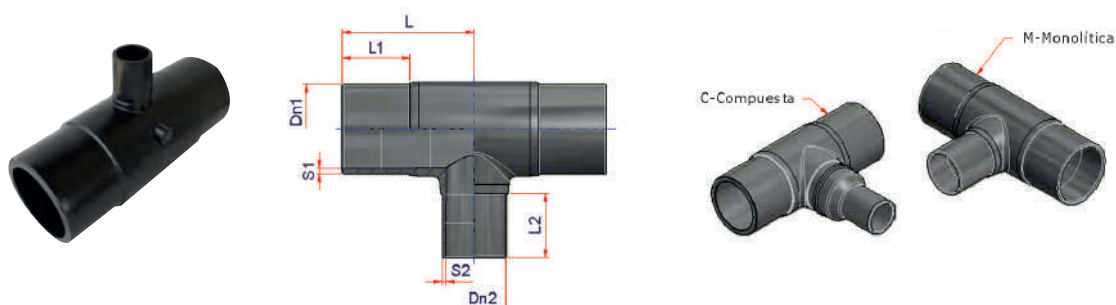

Referencia	Ø (mm)	Dn1 (mm)	S1 (mm)	L1 (mm)	Dn2 (mm)	S2 (mm)	L2 (mm)	L (mm)	Uds. Caja	Precio (€/u.)
ETRS2263	225-63	225	20,5	120	63	5,8	58	261	10	211,26
ETRS2290	225-90	225	20,5	125	90	8,2	90	240	10	204,05
ETRS2211	225-110	225	20,5	125	110	10,0	87	240	10	204,87
ETRS2212	225-125	225	20,5	125	125	11,4	95	240	10	211,26
ETRS2216	225-160	225	20,5	120	160	14,6	110	261	10	205,59
ETRS2218	225-180	225	20,5	120	180	16,4	110	261	10	242,07
ETRS2590	250-90	250	22,7	134	90	8,2	90	255	12	625,33
ETRS2511	250-110	250	22,7	134	110	10,0	116	255	17	625,33
ETRS2512	250-125	250	22,7	134	125	11,4	95	255	1	242,07
ETRS2516	250-160	250	22,7	134	160	14,6	105	255	10	340,40
ETRS2520	250-200	250	22,7	134	200	18,2	116	255	8	625,33
ETRS2811	280-110	280	25,4	150	110	10,0	170	520	1	1.025,80
ETRS2820	280-200	280	25,4	150	200	18,2	150	520	1	1.025,80
ETRS2822	280-225	280	25,4	150	225	20,5	120	520	1	1.025,80
ETRS2825	280-250	280	25,4	150	250	22,7	170	520	1	1.025,80
ETRS3190	315-90	315	28,6	150	90	8,2	150	360	1	1.077,10
ETRS3111	315-110	315	28,6	150	110	10,0	150	360	3	753,97
ETRS3116	315-160	315	28,6	150	160	14,6	150	360	9	753,97
ETRS3118	315-180	315	28,6	150	180	16,4	110	360	1	1.077,10
ETRS3120	315-200	315	28,6	150	200	18,2	150	360	3	1.077,10
ETRS3122	315-225	315	28,6	150	225	20,5	150	360	3	1.077,10

Accesorios inyectados polivalentes

Reducción larga

PE100 RC SDR11 PFA/PN16

Descripción

- Accesorio inyectado a soldar por electrofusión o a tope.
- Según stock producción, el accesorio se puede suministrar inyectado o manipulado.

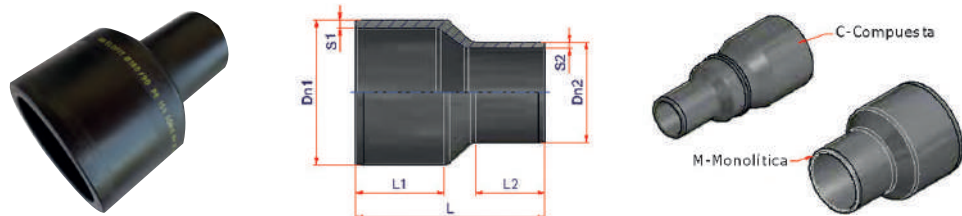

Referencia	Ø (mm)	Dn1 (mm)	S1 (mm)	L1 (mm)	Dn2 (mm)	S2 (mm)	L2 (mm)	L (mm)	Uds. Caja	Precio (€/u.)
ERD 3225	32-25	32	3,0	45	25	3,0	35	88	96	2,21
ERD 4025	40-25	40	3,7	50	25	3,0	45	100	54	3,83
ERD 4032	40-32	40	3,7	49	32	3,0	43	100	60	3,83
ERD 5025	50-25	50	4,6	55	25	3,0	45	110	60	4,22
ERD 5032	50-32	50	4,6	57	32	3,0	41	113	60	4,22
ERD 5040	50-40	50	4,6	57	40	3,7	49	110	30	4,22
ERD 6325	63-25	63	5,8	65	25	3,0	45	133	18	5,18
ERD 6332	63-32	63	5,8	57	32	3,0	44	129	30	5,26
ERD 6340	63-40	63	5,8	57,5	40	3,7	47	122	22	5,26
ERD 6350	63-50	63	5,8	60	50	4,6	54	139	16	5,26
ERD 7540	75-40	75	6,8	64	40	3,7	51	140	20	11,67
ERD 7550	75-50	75	6,8	64	50	4,6	48	140	22	7,75
ERD 7563	75-63	75	6,8	66	63	5,8	44	140	14	7,75
ERD 9050	90-50	90	8,2	73	50	4,6	58	151	12	11,16
ERD 9063	90-63	90	8,2	73	63	5,8	55	148	12	10,86
ERD 9075	90-75	90	8,2	78	75	6,8	72	174	9	10,96
ERD 1150	110-50	110	10,0	90	50	4,6	55	178	5	15,85
ERD 1163	110-63	110	10,0	85	63	5,8	64	175	6	14,60
ERD 1175	110-75	110	10,0	86	75	6,8	57	183	6	15,09
ERD 1190	110-90	110	10,0	76	90	8,2	68	171	26	14,60
ERD 1263	125-63	125	11,4	87	63	5,8	55	185	24	17,54
ERD 1275	125-75	125	11,4	90	75	6,8	60	195	20	18,99
ERD 1290	125-90	125	11,4	85	90	8,2	69	183	26	18,14
ERD 1211	125-110	125	11,4	89	110	10,0	80	185	20	18,14
ERD 1490	140-90	140	12,7	102	90	8,2	90	220	16	32,31
ERD 1411	140-110	140	12,7	95	110	10,0	85	205	22	36,72
ERD 1412	140-125	140	12,7	92	125	11,4	90	205	15	28,17
ERD 1690	160-90	160	14,6	108	90	8,2	90	230	12	35,49
ERD 1611	160-110	160	14,6	103	110	10,0	88	215	12	35,59
ERD 1612	160-125	160	14,6	102	125	11,4	91	214	12	35,59
ERD 1614	160-140	160	14,6	100	140	12,7	94	212	10	35,80
ERD 1812	180-125	180	16,4	107	125	11,4	90	218	24	46,13
ERD 1814	180-140	180	16,4	100	140	12,7	82	-	10	64,81
ERD 1816	180-160	180	16,4	107	160	14,6	100	222	24	46,13

Accesorios inyectados polivalentes

Reducción larga

PE100 RC SDR11 PFA/PN16

Descripción

- Accesorio inyectado a soldar por electrofusión o a tope.
- Según stock producción, el accesorio se puede suministrar inyectado o manipulado.

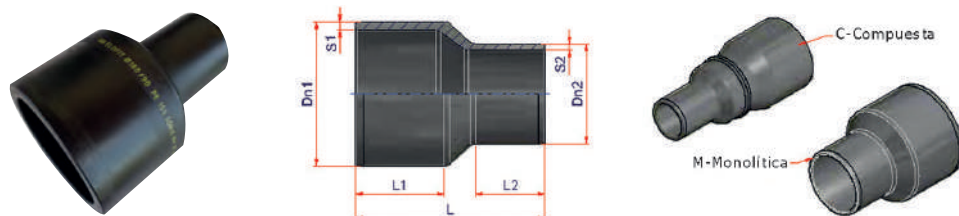

Referencia	∅ (mm)	Dn1 (mm)	S1 (mm)	L1 (mm)	Dn2 (mm)	S2 (mm)	L2 (mm)	L (mm)	Uds. Caja	Precio (€/u.)
ERD 2014	200-140	200	18,2	110	140	12,7	100	240	20	66,29
ERD 2016	200-160	200	18,2	118	160	14,6	101	240	24	50,55
ERD 2018	200-180	200	18,2	113,5	180	16,4	108,5	237	24	65,87
ERD 2216	225-160	225	20,5	122	160	14,6	100	252	16	81,33
ERD 2218	225-180	225	20,5	122	180	16,4	107	252	10	81,33
ERD 2220	225-200	225	20,5	121	200	18,2	113	255	12	81,33
ERD 2518	250-180	250	22,7	130	180	16,4	105	280	12	118,62
ERD 2520	250-200	250	22,7	130	200	18,2	115	280	12	115,03
ERD 2522	250-225	250	22,7	125	225	20,5	120	255	6	115,03
ERD 2820	280-200	280	25,4	142	200	18,2	115	292	1	234,08
ERD 2822	280-225	280	25,4	142	225	20,5	123	295	5	188,60
ERD 2825	280-250	280	25,4	140	250	22,7	130	287	5	153,29
ERD 3122	315-225	315	28,6	152	225	20,5	122	305	16	197,23
ERD 3125	315-250	315	28,6	152	250	22,7	131	305	16	197,23
ERD 3128	315-280	315	28,6	152	280	25,4	141	315	9	248,22
ERD 3525	355-250	355	32,3	172	250	22,7	146	-	6	Consultar
ERD 3528	355-280	355	32,3	170	280	25,4	142	358	6	Consultar
ERD 3531	355-315	355	32,3	170	315	28,6	155	360	6	Consultar
ERD 4028	400-280	400	36,4	185	280	25,4	153	450	6	Consultar
ERD 4031	400-315	400	36,4	185	315	28,6	160	400	6	Consultar
ERD 4035	400-355	400	36,4	182	355	32,3	170	382	6	Consultar

Accesorios inyectados polivalentes

Reducción corta

PE100 RC SDR11 PFA/PN16

Descripción

- Accesorio a soldar a tope.
- Entrega: 15 días desde el pedido.

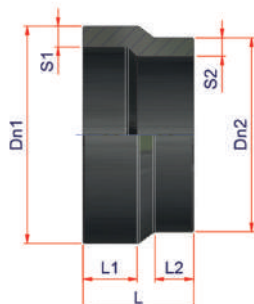

Referencia	Ø (mm)	Dn1 (mm)	S1 (mm)	L1 (mm)	Dn2 (mm)	S2 (mm)	L2 (mm)	L (mm)	Uds. Caja	Precio (€/u.)
ERDC 2016	200-160	200	18,2	55	160	14,6	50	125	1	51,12
ERDC2018	200-180	200	18,2	61	180	16,4	45	130	1	51,12
ERDC2216	225-160	225	20,5	51	160	14,6	31	110	24	71,81
ERDC2218	225-180	225	20,5	51	180	16,4	31	105	9	71,81
ERDC2220	225-200	225	20,5	50	200	18,2	33	100	1	71,81
ERDC2518	250-180	250	22,7	50	180	16,4	45	130	8	102,87
ERDC 2520	250-200	250	22,7	58	200	18,2	56	147	18	102,87
ERDC 2522	250-225	250	22,7	52	225	20,5	33	100	18	102,87
ERDC 2820	280-200	280	25,4	80	200	18,2	35	145	15	105,08
ERDC 2822	280-225	280	25,4	70	225	20,5	46	146	15	105,08
ERDC 2825	280-250	280	25,4	70	250	22,7	50	143	10	105,08
ERDC 3120	315-200	315	28,6	55	200	18,2	55	166	1	125,56
ERDC 3122	315-225	315	28,6	55	225	20,5	55	158	12	125,56
ERDC 3125	315-250	315	28,6	55	250	22,7	55	150	20	125,56
ERDC 3128	315-280	315	28,6	55	280	25,4	55	150	12	125,56
ERDC 3525	355-250	355	32,3	45	250	22,7	34	220	13	Consultar
ERDC 3528	355-280	355	32,3	85	280	25,4	75	200	10	Consultar
ERDC 3531	355-315	355	32,3	45	315	28,6	10	110	24	Consultar
ERDC 4028	400-280	400	36,4	95	280	25,4	73	227	1	Consultar
ERDC 4031	400-315	400	36,4	55	315	28,6	45	128	25	Consultar
ERDC 4035	400-355	400	36,4	52	355	32,3	53	136	8	Consultar
ERDC 4531	450-315	450	40,9	62	315	28,6	84	224	1	Consultar
ERDC 4535	450-355	450	40,9	75	355	32,3	15	100	1	Consultar
ERDC 450400	450-400	450	40,9	50	400	36,4	45	120	1	Consultar
ERDC 5035	500-355	500	45,5	73	355	32,3	18	100	8	Consultar
ERDC 500400	500-400	500	45,5	70	400	36,4	30	150	10	Consultar
ERDC 500450	500-450	500	45,5	70	450	40,9	30	150	1	Consultar
ERDC 5640	560-400	560	50,9	53	400	36,4	98	240	1	Consultar
ERDC 5645	560-450	560	50,9	82	450	40,9	30	152	1	Consultar
ERDC 560500	560-500	560	50,9	81	500	45,5	35	152	1	Consultar
ERDC 6345	630-450	630	57,3	58	450	40,9	65	230	1	Consultar
ERDC 6350	630-500	630	57,3	63	500	45,5	62	206	1	Consultar
ERDC 6356	630-560	630	57,3	63	560	50,9	63	186	1	Consultar

Accesorios inyectados polivalentes

Tapón largo

PE100 RC SDR11 PFA/PN16

Descripción

- Accesorio inyectado a soldar por electrofusión o a tope .
- *Obtenido de un tapón corto + tubo.
- ** Obtenido de 12ERD4031 + 12ECAL315.

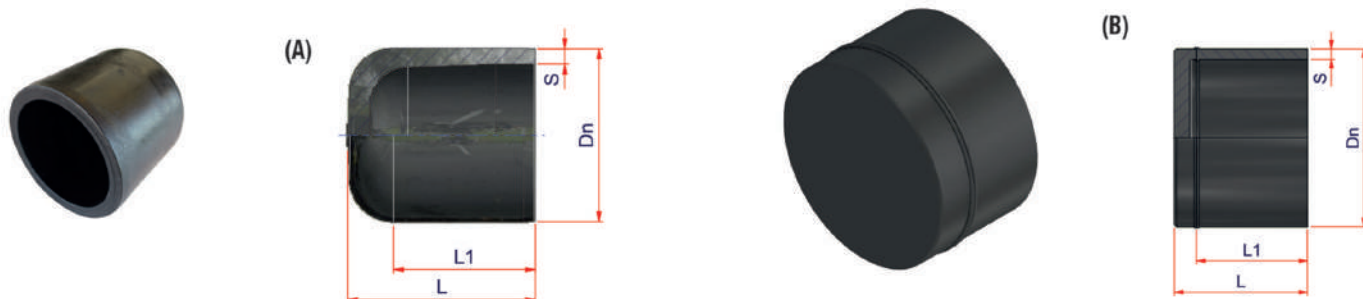

Referencia	Tipo	Ø (mm)	Dn (mm)	S (mm)	L1 (mm)	L (mm)	Uds. Caja	Precio (€/u.)
ECAL 20	A	20	20	3,0	50	56	350	2,69
ECAL 25	A	25	25	3,0	50	57	150	1,98
ECAL 32	A	32	32	3,0	50	59	450	2,51
ECAL 40	A	40	40	3,7	55	66	250	3,08
ECAL 50	A	50	50	4,6	60	74	150	4,05
ECAL 63	A	63	63	5,8	70	87	80	5,61
ECAL 75	A	75	75	6,8	75	95	45	8,69
ECAL 90	A	90	90	8,2	81	105	30	12,52
ECAL 110	A	110	110	10,0	90	119	40	16,98
ECAL 125	A	125	125	11,4	95	128	27	18,35
ECAL 140	A	140	140	12,7	100	116	24	25,94
ECAL 160	A	160	160	14,6	108	142	16	27,31
ECAL 180	A	180	180	16,4	95	113	15	35,20
ECAL 200	A	200	200	18,2	133	172	4	41,67
ECAL 225	A	225	225	20,5	127	145	5	91,75
ECAL 250	A	250	250	22,7	117	150	5	99,27
ECAL 280	A	280	280	25,4	112	117	2	125,66
ECAL 315 *	B	315	315	28,6	157	208	24	205,04
ECAL 355 *	B	355	355	32,3	145	245	4	Consultar
ECAL 400 **	B	400	400	36,4	178	300	4	Consultar
ECAL 450 *	B	450	450	40,9	-	-	1	Consultar
ECAL 500 *	B	500	500	45,5	-	-	5	Consultar
ECAL 560 *	B	560	560	50,9	-	-	1	Consultar
ECAL 630 *	B	630	630	57,3	-	-	1	Consultar



Accesorios inyectados polivalentes PE100 RC SDR17 PN10

Con Declaración Ambiental de Producto (DAP)



Accesorios inyectados polivalentes

Codo 90° largo

PE100 RC SDR17 PFA/PN10

Descripción

- Accesorio inyectado a soldar por electrofusión o a tope.
- * Accesorio de codo corto prolongado con tubo PE.

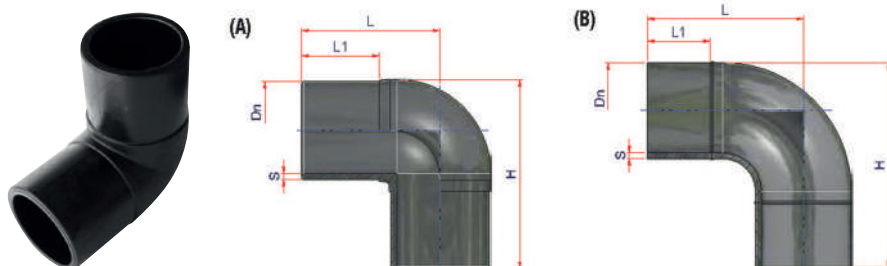

Referencia	Tipo	Ø (mm)	Dn (mm)	S (mm)	L1 (mm)	L (mm)	H (mm)	Uds. Caja	Precio (€/u.)
DG 63	A	63	63	3,8	70	120	154	50	6,28
DG 75	A	75	75	4,5	75	130	171	30	9,62
DG 90	A	90	90	5,4	89	146	197	24	11,90
DG 110	A	110	110	6,6	87	155	212,5	12	25,06
DG 125	A	125	125	7,4	95	185	250,5	24	31,83
DG 140	A	140	140	8,3	97	195	268	20	46,21
DG 160	A	160	160	9,5	101	210	293,5	18	50,98
DG 180	A	180	180	10,7	109	230	323,5	18	63,01
DG 200	A	200	200	11,9	116	250	354	16	78,20
DG 225	A	225	225	13,4	125	275	392	12	96,62
DG 250	A	250	250	14,8	135	305	435	10	150,42
DG 280	A	280	280	16,6	140	340	485	6	302,21
DG 315	A	315	315	18,7	165	360	518	4	343,31
DG 355*	B	355	355	21,1	210	550	727,5	2	Consultar
DG 400*	B	400	400	23,7	300	640	840	2	Consultar
DG 450*	B	450	450	26,7	300	745	970	2	Consultar
DG 500*	B	500	500	29,7	300	745	995	1	Consultar

Codo 90° corto

PE100 RC SDR17 PFA/PN10

Descripción

- Accesorio inyectado a soldar por electrofusión o a tope.

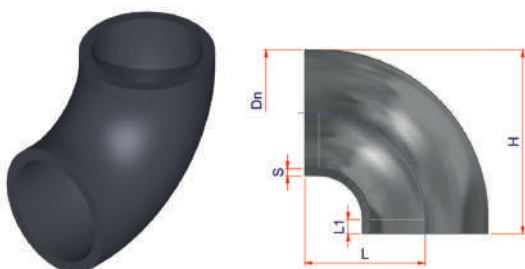

Referencia	Ø (mm)	Dn (mm)	S (mm)	L1 (mm)	L (mm)	H (mm)	Uds. Caja	Precio (€/u.)
DGC 355	355	355	21,1	35	340	517,5	1	Consultar
DGC 400	400	400	23,7	40	340	540	1	Consultar
DGC 450	450	450	26,7	45	445	670	2	Consultar
DGC 500	500	500	29,7	50	445	695	1	Consultar

Accesorios inyectados polivalentes

Codo 45° largo

PE100 RC SDR17 PFA/PN10

Descripción

- Accesorio inyectado a soldar por electrofusión o a tope.
- * Accesorio de codo corto prolongado con tubo PE.

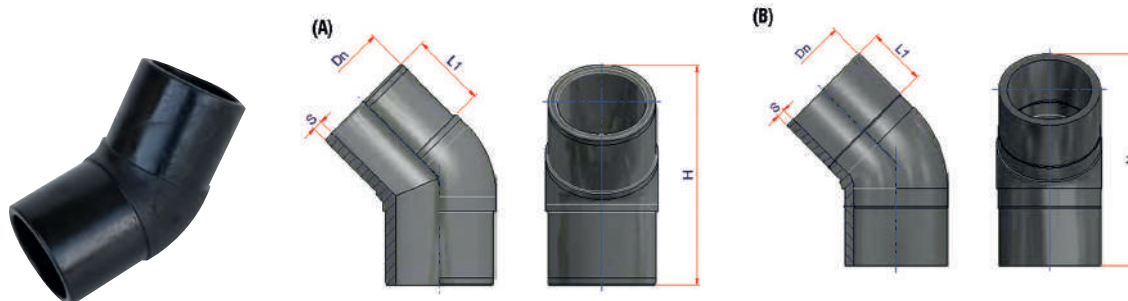

Referencia	Tipo	Ø (mm)	Dn (mm)	S (mm)	L1 (mm)	H (mm)	Uds. Caja	Precio (€/u.)
DC 63	A	63	63	3,8	70	175	60	8,56
DC 75	A	75	75	4,5	75	205	40	10,60
DC 90	A	90	90	5,4	90	235	25	13,35
DC 110	A	110	110	6,6	87	242	16	25,57
DC 125	A	125	125	7,4	95	264,5	10	31,51
DC 140	A	140	140	8,3	97	287	8	41,31
DC 160	A	160	160	9,5	103	311	14	47,80
DC 180	A	180	180	10,7	110	369	16	52,20
DC 200	A	200	200	11,9	117	402	16	71,39
DC 225	A	225	225	13,4	125	436	15	85,18
DC 250	A	250	250	14,8	135	462	12	165,23
DC 280	A	280	280	16,6	140	520	8	310,50
DC 315	A	315	315	18,7	160	570	8	359,84
DC 355*	B	355	355	21,1	210	700	3	Consultar
DC 400*	B	400	400	23,7	300	860	4	Consultar
DC 450*	B	450	450	26,7	300	960	1	Consultar
DC 500*	B	500	500	29,7	300	980	1	Consultar

Accesorios inyectados polivalentes

Te 90° larga PE100 RC SDR17 PFA/PN10

Descripción

-Accesorio inyectado a soldar por electrofusión o a tope.

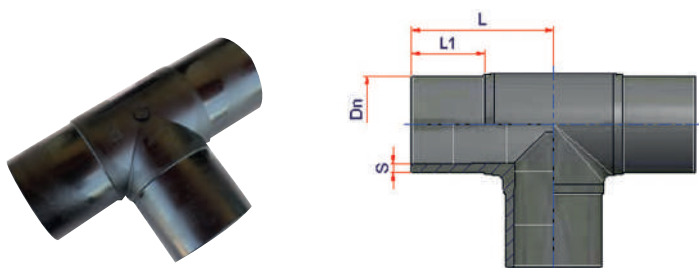

Referencia	Ø (mm)	Dn (mm)	S (mm)	D (mm)	L1 (mm)	L (mm)	H (mm)	Uds. Caja	Precio (€/u.)
DT 63	63	63	3,8	68	70	240	154	30	7,94
DT 75	75	75	4,5	82	75	260	171	20	12,91
DT 90	90	90	5,4	97,5	90	297	197	15	18,56
DT 110	110	110	6,6	122	87	320	221	9	27,24
DT 125	125	125	7,4	131	95	370	250,5	5	37,39
DT 140	140	140	8,3	146,5	97	390	268	30	60,06
DT 160	160	160	9,5	167	103	420	293,5	8	77,98
DT 180	180	180	10,7	187,5	110	460	324	13	102,30
DT 200	200	200	11,9	208,5	117	500	354	10	146,52
DT 225	225	225	13,4	234,5	125	550	392	9	174,15
DT 250	250	250	14,8	260,5	135	610	435	7	222,54
DT 280	280	280	16,6	288	155	650	469	4	401,00
DT 315	315	315	18,7	328,5	169	717	523	3	454,62
DT 355	355	355	21,3	370	166	826	598	3	Consultar
DT 400	400	400	23,7	415	197	940	677,5	1	Consultar

Accesorios inyectados polivalentes

Te 90° reducida larga PE100 RC SDR17 PFA/PN10

Descripción

- Accesorio inyectado a soldar por electrofusión o a tope.
- Según stock producción, el accesorio se puede suministrar inyectado o manipulado.

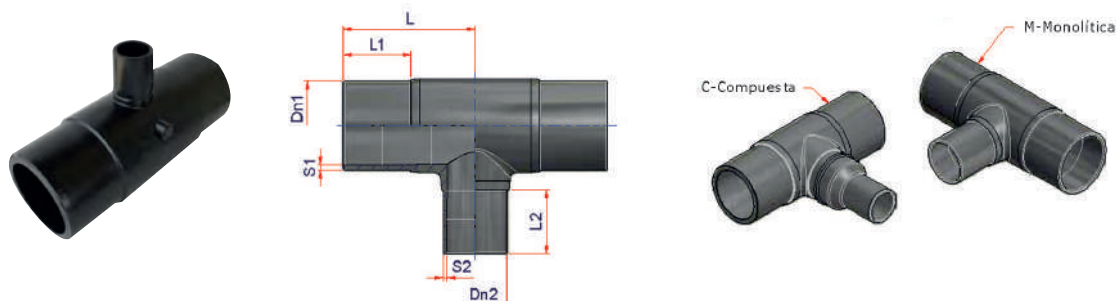

Referencia	Ø (mm)	Dn1 (mm)	S1 (mm)	L1 (mm)	Dn2 (mm)	S2 (mm)	L2 (mm)	L (mm)	Uds. Caja	Precio (€/u.)
DTRS9050	90-50	90	5,4	84	50	3,0	60	127	1	37,99
DTRS9063	90-63	90	5,4	84	63	3,8	70	127	16	38,15
DTRS9075	90-75	90	5,4	90	75	4,5	75	148,5	1	37,99
DTRS1150	110-50	110	6,6	87	50	3,0	70	155	1	43,87
DTRS1163	110-63	110	6,6	87	63	3,8	87	155	8	30,71
DTRS1175	110-75	110	6,6	87	75	4,5	78	155	22	43,87
DTRS1190	110-90	110	6,6	87	90	5,4	90	155	10	30,71
DTRS1263	125-63	125	7,4	95	63	3,8	70	185	1	55,83
DTRS1275	125-75	125	7,4	95	75	4,5	75	185	1	55,82
DTRS1290	125-90	125	7,4	95	90	5,4	90	185	5	51,13
DTRS1211	125-110	125	7,4	95	110	6,6	87	185	15	51,13
DTRS1463	140-63	140	8,3	105	63	3,8	77	193	12	78,75
DTRS1475	140-75	140	8,3	105	75	4,5	78	193	12	81,33
DTRS1490	140-90	140	8,3	105	90	5,4	87	193	14	81,33
DTRS1411	140-110	140	8,3	105	110	6,6	95	193	20	82,35
DTRS1663	160-63	160	9,5	103	63	3,8	70	190	11	86,84
DTRS1675	160-75	160	9,5	103	75	4,5	75	190	1	86,84
DTRS1690	160-90	160	9,5	103	90	5,4	90	190	8	86,84
DTRS1611	160-110	160	9,5	103	110	6,6	87	190	9	86,84
DTRS1612	160-125	160	9,5	103	125	7,4	95	190	1	124,05
DTRS1875	180-75	180	10,7	116	75	4,5	93	230	6	130,71
DTRS1890	180-90	180	10,7	116	90	5,4	84	230	6	116,49
DTRS1811	180-110	180	10,7	116	110	6,6	95	230	5	138,20
DTRS1812	180-125	180	10,7	116	125	7,4	100	230	18	145,63
DTRS1814	180-140	180	10,7	116	140	8,3	104	230	5	117,73
DTRS1816	180-160	180	10,7	116	160	9,5	110	230	5	146,39
DTRS2063	200-63	200	11,9	117	63	3,8	70	230	1	151,73
DTRS2075	200-75	200	11,9	117	75	4,5	75	230	1	151,73
DTRS2090	200-90	200	11,9	117	90	5,4	90	230	1	161,14
DTRS2011	200-110	200	11,9	117	110	6,6	87	230	20	147,30
DTRS2012	200-125	200	11,9	117	125	7,4	95	230	1	147,29
DTRS2016	200-160	200	11,9	117	160	9,5	103	230	5	151,73

Accesorios inyectados polivalentes

Te 90° reducida larga PE100 RC SDR17 PFA/PN10

Descripción

- Accesorio inyectado a soldar por electrofusión o a tope.
- Según stock producción, el accesorio se puede suministrar inyectado o manipulado.

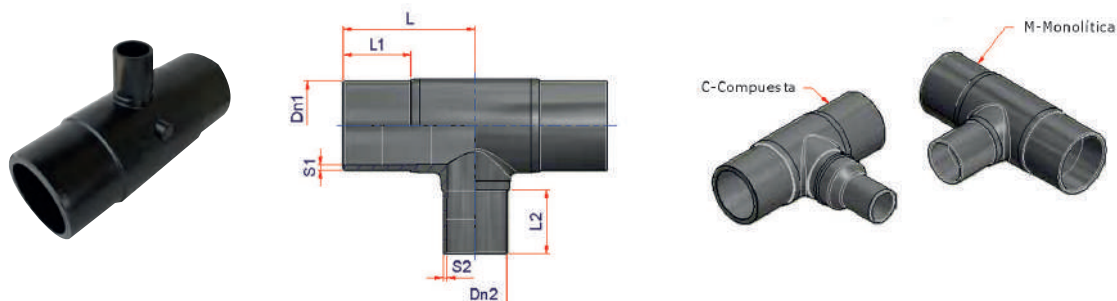

Referencia	Ø (mm)	Dn1 (mm)	S1 (mm)	L1 (mm)	Dn2 (mm)	S2 (mm)	L2 (mm)	L (mm)	Uds. Caja	Precio (€/u.)
DTRS2263	225-63	225	13,4	120	63	3,8	100	261	10	189,91
DTRS2290	225-90	225	13,4	120	90	5,4	100	261	16	183,83
DTRS2211	225-110	225	13,4	120	110	6,6	100	261	10	184,44
DTRS2212	225-125	225	13,4	120	125	7,4	100	261	13	204,19
DTRS2216	225-160	225	13,4	120	160	9,5	100	261	10	184,95
DTRS2218	225-180	225	13,4	120	180	10,7	100	261	2	285,75
DTRS2590	250-90	250	14,8	134	90	5,4	90	255	1	262,66
DTRS2511	250-110	250	14,8	134	110	6,6	116	255	11	581,64
DTRS2512	250-125	250	14,8	134	125	7,4	95	255	17	581,64
DTRS2516	250-160	250	14,8	134	160	9,5	105	255	10	408,86
DTRS2520	250-200	250	14,8	134	200	11,9	116	255	1	262,66
DTRS2811	280-110	280	16,6	150	110	6,6	170	520	6	757,93
DTRS2822	280-225	280	16,6	150	225	13,4	120	520	6	757,93
DTRS3111	315-110	315	18,7	150	110	6,6	150	360	4	1.465,24
DTRS3116	315-160	315	18,7	150	160	9,5	150	360	9	1.482,11
DTRS3120	315-200	315	18,7	150	200	11,9	150	360	3	858,87
DTRS3122	315-225	315	18,7	150	225	13,4	150	360	5	858,87

Accesorios inyectados polivalentes

Reducción larga

PE100 RC SDR17 PFA/PN10

Descripción

- Accesorio inyectado a soldar por electrofusión o a tope.
- Según stock producción, el accesorio se puede suministrar inyectado o manipulado.

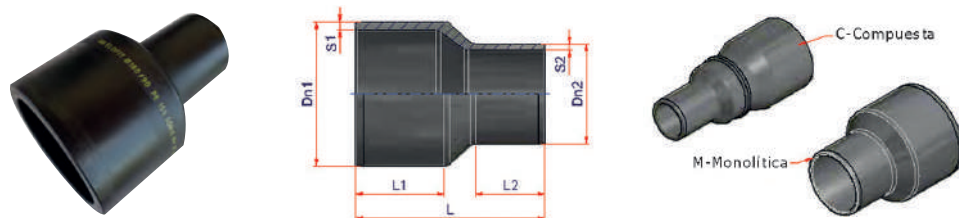

Referencia	Ø (mm)	Dn1 (mm)	S1 (mm)	L1 (mm)	Dn2 (mm)	S2 (mm)	L2 (mm)	L (mm)	Uds. Caja	Precio (€/u.)
DRD 7563	75-63	75	4,5	66	63	3,8	44	140	14	7,75
DRD 9050	90-50	90	5,4	73	50	3,0	58	151	12	11,20
DRD 9063	90-63	90	5,4	73	63	3,8	55	148	12	10,86
DRD 9075	90-75	90	5,4	78	75	4,5	72	174	9	10,96
DRD 1163	110-63	110	6,6	84	63	3,8	63	171	6	14,60
DRD 1175	110-75	110	6,6	86	75	4,5	57	183	6	15,09
DRD 1190	110-90	110	6,6	76	90	5,4	68	171	6	14,60
DRD 1263	125-63	125	7,4	87	63	3,8	55	183	30	17,54
DRD 1275	125-75	125	7,4	90	75	4,5	60	195	18	18,27
DRD 1290	125-90	125	7,4	85	90	5,4	69	183	30	17,54
DRD 1211	125-110	125	7,4	88	110	6,6	75	185	20	17,54
DRD 1490	140-90	140	8,3	102	90	5,4	90	220	20	30,13
DRD 1411	140-110	140	8,3	95	110	6,6	85	205	16	30,13
DRD 1412	140-125	140	8,3	92	125	7,4	90	205	15	25,26
DRD 1690	160-90	160	9,5	105	90	5,4	90	225	12	33,72
DRD 1611	160-110	160	9,5	103	110	6,6	88	215	12	33,81
DRD 1612	160-125	160	9,5	102	125	7,4	91	214	12	33,81
DRD 1614	160-140	160	9,5	100	140	8,3	94	212	8	34,01
DRD 1812	180-125	180	10,7	112	125	7,4	90	242	30	43,82
DRD 1814	180-140	180	10,7	100	140	8,3	82	218	30	62,39
DRD 1816	180-160	180	10,7	107	160	9,5	100	222	20	43,82
DRD 2014	200-140	200	11,9	110	140	8,3	100	240	6	61,48
DRD 2016	200-160	200	11,9	100,5	160	9,5	94	237,5	30	50,55
DRD 2018	200-180	200	11,9	113,5	180	10,7	108,5	235	12	65,89
DRD 2216	225-160	225	13,4	122	160	9,5	100	252	16	81,33
DRD 2218	225-180	225	13,4	122	180	10,7	107	252	16	83,88
DRD 2220	225-200	225-200	13,4	121	200	11,9	113	255	12	100,94

Accesorios inyectados polivalentes

Reducción larga

PE100 RC SDR17 PFA/PN10

Descripción

- Accesorio inyectado a soldar por electrofusión o a tope.
- Según stock producción, el accesorio se puede suministrar inyectado o manipulado.

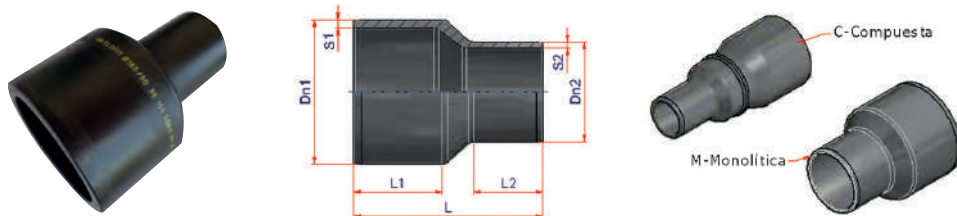

Referencia	Ø (mm)	Dn1 (mm)	S1 (mm)	L1 (mm)	Dn2 (mm)	S2 (mm)	L2 (mm)	L (mm)	Uds. Caja	Precio (€/u.)
DRD 2518	250-180	250	14,8	130	180	10,7	105	280	12	132,59
DRD 2520	250-200	250	14,8	130	200	11,9	115	280	12	115,03
DRD 2522	250-225	250	14,8	130	225	13,4	121	268	6	115,03
DRD 2820	280-200	280	16,6	142	200	11,9	115	292	6	236,89
DRD 2822	280-225	280	16,6	142	225	13,4	123	295	5	236,89
DRD 2825	280-250	280	16,6	140	250	14,8	130	287	5	153,29
DRD 3122	315-225	315	18,7	152	225	13,4	122	305	16	195,86
DRD 3125	315-250	315	18,7	152	250	14,8	131	305	16	195,86
DRD 3128	315-280	315	18,7	152	280	16,6	141	315	4	275,16
DRD 3525	355-250	355	21,1	170	250	14,8	132	358	6	Consultar
DRD 3528	355-280	355	21,1	170	280	16,6	142	-	6	Consultar
DRD 3531	355-315	355	21,1	170	315	18,7	155	-	6	Consultar
DRD 4028	400-280	400	23,7	187	280	16,6	153	450	10	Consultar
DRD 4031	400-315	400	23,7	185	315	18,7	155	380	6	Consultar
DRD 4035	400-355	400	23,7	185	355	21,1	170	400	12	Consultar
DRD 4531	450-315	450	26,7	202	315	18,7	157	405	1	Consultar
DRD 4540	450-400	450	26,7	205	400	23,7	190	435	4	Consultar
DRD500400	500-400	500	29,7	205	400	23,7	190	435	1	Consultar

Accesorios inyectados polivalentes

Reducción corta

PE100 RC SDR17 PFA/PN10

Descripción

- Accesorio a soldar a tope.
- Entrega: 15 días desde el pedido.

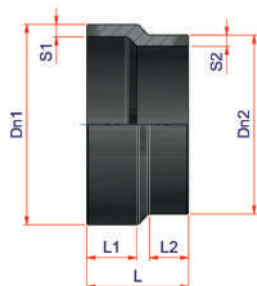

Referencia	Ø (mm)	Dn1 (mm)	S1 (mm)	L1 (mm)	Dn2 (mm)	S2 (mm)	L2 (mm)	L (mm)	Uds. Caja	Precio (€/u.)
DRDC2016	200-160	200	11,9	50	160	9,5	40	120	1	47,63
DRDC2018	200-180	200	11,9	50	180	10,7	45	120	1	47,63
DRDC2216	225-160	225	13,4	50	160	9,5	40	120	1	68,38
DRDC2218	225-180	225	13,4	50	180	10,7	30	105	12	68,38
DRDC2220	225-200	225	13,4	50	200	11,9	40	103	1	68,38
DRDC2518	250-180	250	14,8	50	180	10,7	50	125	1	88,06
DRDC 2520	250-200	250	14,8	50	200	11,9	33	100	7	88,06
DRDC 2522	250-225	250	14,8	52	225	13,4	33	100	18	88,06
DRDC 2820	280-200	280	16,6	80	200	11,9	35	145	20	99,84
DRDC 2822	280-225	280	16,6	65	225	13,4	50	150	15	99,84
DRDC 2825	280-250	280	16,6	70	250	14,8	55	143	10	99,84
DRDC 3120	315-200	315	18,8	55	200	11,9	55	170	1	105,91
DRDC 3122	315-225	315	18,8	55	225	13,4	55	162,5	16	105,91
DRDC 3125	315-250	315	18,8	55	250	14,8	55	152,5	6	105,91
DRDC 3128	315-280	315	18,8	50	280	16,6	50	117	12	105,91
DRDC 3525	355-250	355	21,1	50	250	14,8	36	134	10	Consultar
DRDC 3528	355-280	355	21,1	46	280	16,6	45	128	10	Consultar
DRDC 3531	355-315	355	21,1	45	315	18,8	40	110	8	Consultar
DRDC4028	400-280	400	23,7	40	280	16,6	50	130	1	Consultar
DRDC4031	400-315	400	23,7	55	315	18,8	45	128	12	Consultar
DRDC4035	400-355	400	23,7	50	355	21,1	54	135	8	Consultar
DRDC4531	450-315	450	26,7	73	315	18,8	37	145	1	Consultar
DRDC4535	450-355	450	26,7	40	355	21,1	50	130	1	Consultar
DRDC4540	450-400	450	26,7	50	400	23,7	45	128	9	Consultar
DRDC5035	500-355	500	29,7	40	355	21,1	45	130	1	Consultar
DRDC5040	500-400	500	29,7	60	400	23,7	45	150	1	Consultar
DRDC5045	500-450	500	29,7	55	450	26,7	35	120	10	Consultar
DRDC5640	560-400	560	33,2	71	400	23,7	40	155	1	Consultar
DRDC5645	560-450	560	33,2	80	450	26,7	30	153	1	Consultar
DRDC5650	560-500	560	33,2	80	500	29,7	35	153	1	Consultar
DRDC6345	630-450	630	37,4	80	450	26,7	40	150	1	Consultar
DRDC6350	630-500	630	37,4	80	500	29,7	40	155	1	Consultar
DRDC6356	630-560	630	37,4	80	560	33,2	40	155	1	Consultar
DRDC7163	710-630	710	41,8	66	630	37,4	62	160	1	Consultar

Accesorios inyectados polivalentes

Tapón largo

PE100 RC SDR17 PFA/PN10

Descripción

- Accesorio inyectado a soldar por electrofusión o a tope.
- *Obtenido de un tapón corto + tubo.

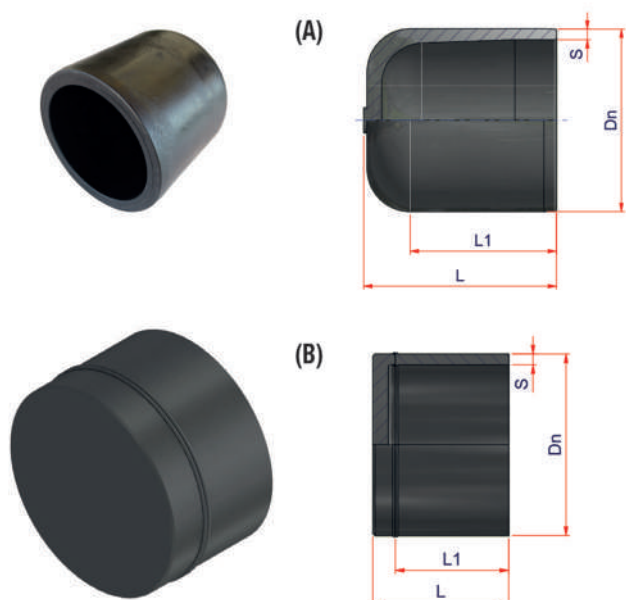

Referencia	Tipo	Ø (mm)	Dn (mm)	S (mm)	L1 (mm)	L (mm)	Uds. Caja	Precio (€/u.)
DCAL 63	A	63	63	3,8	70	87	70	6,48
DCAL 75	A	75	75	4,5	75	95	45	10,05
DCAL 90	A	90	90	5,4	81	105	33	15,25
DCAL 110	A	110	110	6,6	88	116	40	20,68
DCAL 125	A	125	125	7,4	95	128	28	22,35
DCAL 140	A	140	140	8,3	100	116	22	27,95
DCAL 160	A	160	160	9,5	108	142	16	31,33
DCAL 180	A	180	180	10,7	95	113	12	40,72
DCAL 200	A	200	200	11,9	136	169	4	50,73
DCAL 225	A	225	225	13,4	127	145	24	67,23
DCAL 250	A	250	250	14,8	117	150	18	91,75
DCAL 280	A	280	280	16,6	112	117	2	122,03
DCAL 315 *	B	315	315	18,8	157	208	16	186,48
DCAL 355 *	B	355	355	21,1	145	245	1	Consultar
DCAL 400 *	B	400	400	23,7	178	300	1	Consultar
DCAL 450 *	B	450	450	26,7	180	250	1	Consultar
DCAL 500 *	B	500	500	29,7	200	270	1	Consultar
DCAL 560 *	B	560	560	33,2	220	290	1	Consultar
DCAL 630 *	B	630	630	37,4	240	310	1	Consultar
DCAL 710 *	B	710	710	42,1	-	-	1	Consultar

Máquinas y herramientas

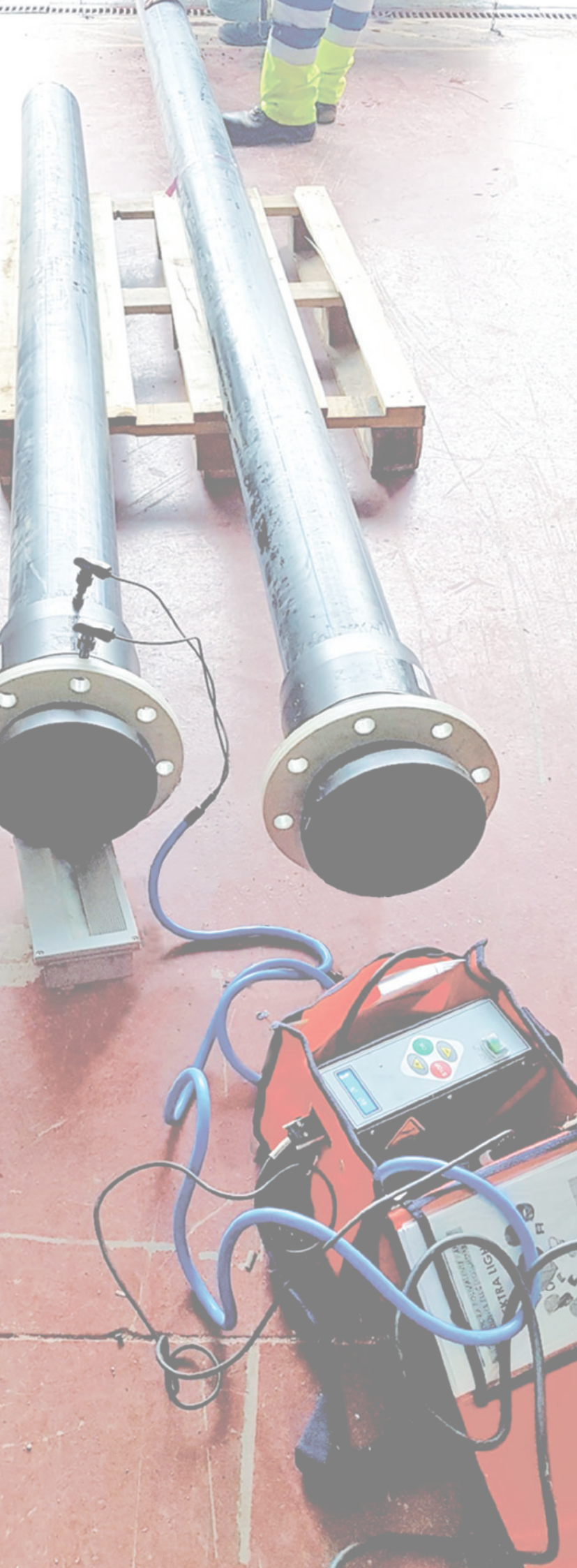

Máquinas de soldadura eléctrica

Máquina de soldar automática polivalente con escáner óptico y sistema Bluetooth integrado



Peso	25,2 kg
Dimensiones	340 x 450 x 220 mm
Potencia máxima absorbida	4.000 VA
Alimentación	230V
Corriente pico	100 A
Corriente soldadura 60% Duty Cycle	73 A
Frecuencia	50 - 60Hz
Temperatura de uso	De -18°C a +55°C
Pantalla	Visor retroiluminado dispuesto en 4 líneas de 20 dígitos
Protección IP	54
Tensión de soldadura	5-42V
Memoria	10.000 ciclos
Diámetros con los que puede trabajar	20 ÷ 630 mm

Referencia	∅ (mm)	Uds. Caja	Precio (€/u.)
E9001E	20÷630	1	Consultar

Máquina de soldar automática "ELEKTRA LIGHT"



Peso	7 kg
Dimensiones	200 x 250 x 210 mm
Potencia máxima absorbida	1.300 W
Alimentación	110V o 230V
Corriente pico	60 A
Corriente soldadura 60% Duty Cycle	23 A
Frecuencia	50 - 60Hz
Temperatura de uso	De -10°C a +40°C
Precisión del termómetro	1°C
Protección IP	54
Tensión de soldadura	8-48V
Memoria	325 ciclos
Diámetros con los que puede trabajar	20 ÷ 125/160 * mm

Referencia	∅ (mm)	Uds. Caja	Precio (€/u.)
96906063	20-125/160* mm	1	Consultar

* Es posible soldar el diámetro 160 mm tomando la precaución de esperar el enfriamiento de la máquina, después de cada soldadura.

Máquina de soldar con scanner "ELEKTRA 315"



Peso	16 kg
Dimensiones	263 x 240 x 300 mm
Potencia máxima absorbida	2.600 W
Alimentación	110V o 230V
Corriente pico	100 A
Corriente soldadura 60% Duty Cycle	60 A
Frecuencia	50 - 60Hz
Temperatura de uso	De -10°C a +50°C
Protección IP	54
Tensión de soldadura	8-48V
Memoria	500 ciclos
Diámetros con los que puede trabajar	20 ÷ 315 mm

Referencia	∅ (mm)	Uds. Caja	Precio (€/u.)
96906126	20-315 mm	1	Consultar

Herramientas - UNI 10521

Rascador giratorio



Referencia	∅ SDR6 – SDR7,4- SDR9 - SDR11	∅ SDR17	Peso (kg)	Uds. Caja	Precio (€/u.)
RAT1A *	75-200 mm	75-180 mm	2,8	1	Consultar
RAT2A **	200-400 mm	200-400 mm	5,5	1	Consultar

* Rascador con bolsa para transporte (RAT1A)

** Rascador con caja metálica (RAT2A)

Alineador para accesorios electrosoldables



Referencia	Tipo	∅	Peso (kg)	Uds. Caja	Precio (€/u.)
99500010	A	20/63 mm	3,0	1	Consultar
99220003	B	63/180 mm	7,5	1	Consultar
99220001	C	125/500 mm	7,5	1	Consultar

SERVICIO DE ALQUILER

Ponemos a disposición del profesional el servicio de alquiler de máquina para sistema electrosoldadura.

Asesoramiento técnico de la máquina más apropiada según la instalación a realizar.

Solicite información y presupuesto:



Italsan Customer Service
atencionalcliente@italsan.com



900 921 957



Italsan Customer Service
atencionalcliente@italsan.com

www.italsan.com

Sede Madrid

Tel. (+34) 918 060 723

Oficinas y Almacén

Coto de Doñana, 21
28320 Pinto - Madrid

Sede Barcelona

Tel. (+34) 936 303 040

Italsantech

C/ de la Màquina, 8B
Pol. Ind. El Regàs
08850 Gavà - Barcelona

Sede Barcelona

Tel. (+34) 936 303 040

Centro logístico

C/ Progrés, 29
Pol. Ind. Les Massotes
08850 Gavà - Barcelona

ITALSAN no se responsabiliza de posibles errores que aparezcan en la presente tarifa y se reserva el derecho a modificar, sin previo aviso, las características y precios* de los productos.

Para cualquier consulta, puede dirigirse a atencionalcliente@italsan.com

*Precios sin IVA

Distribuido por:



TAR/ELOFIT/2023/06